

Model: SGTS-EXT

3Ft Tripod Extension

- Weight Limit **300 lbs.**
- Do Not Over Tighten Fasteners

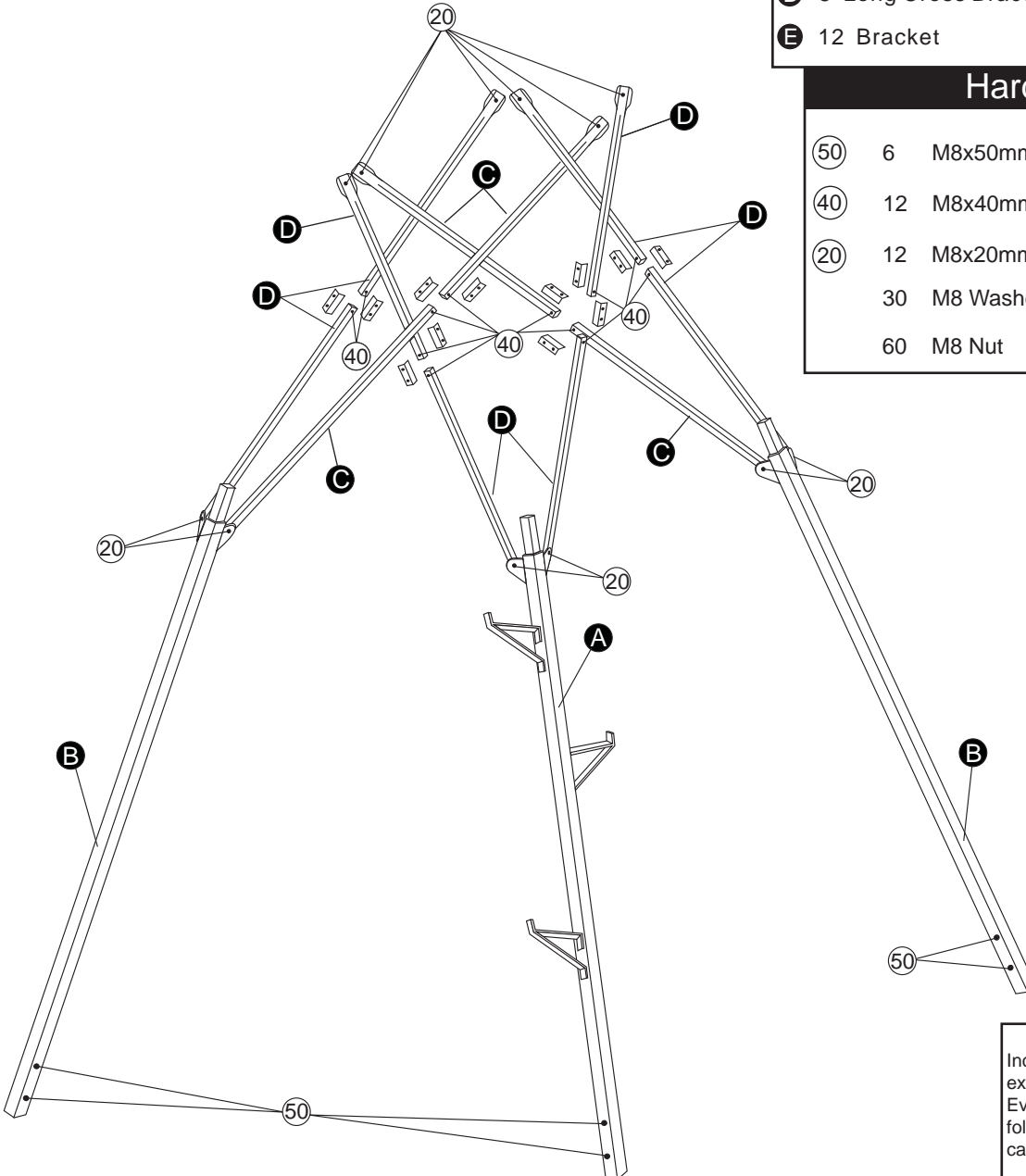

Parts List

| | | |
|----------|---------------------------|----------------|
| A | 1 Bottom Ladder Section | Part # GL-300 |
| B | 2 Bottom Leg | Part # GL-350 |
| C | 4 Short Cross Brace 41.5" | Part # GCB-300 |
| D | 8 Long Cross Brace 47.1" | Part # GCB-350 |
| E | 12 Bracket | Part # GB-300 |

Hardware

| | | |
|-----------|-----------------|-------------|
| 50 | 6 M8x50mm Bolt | Part # 1850 |
| 40 | 12 M8x40mm Bolt | Part # 1840 |
| 20 | 12 M8x20mm Bolt | Part # 1820 |
| | 30 M8 Washer | Part # 1800 |
| | 60 M8 Nut | Part # 1810 |

⚠ Warning ⚠ Warning ⚠ Warning ⚠ Warning ⚠ Warning

1. **ALWAYS** read all warnings and instructions before each use of tripod. Failure to read all warnings and instructions before each use of tripod may result in serious injury or death.
2. Remove all contents from box. Remove all cardboard from the product. Inspect for any damaged or missing pieces. **DO NOT** assemble or use tripod if any parts are missing or damaged. Using the tripod with missing or damaged parts may result in serious injury or death. Missing or damaged parts may be obtained from the address and phone number listed below.
3. **DO NOT** use tripod if any bolts or nuts are loose, bent or crooked.
4. Be sure to retighten all bolts before each new use of tripod.
5. Weight limit of this tripod is **300 lbs.** **DO NOT** use tripod if you or your combined weight with any accessories are more than **300 lbs.** Using this tripod when over **300 lbs.** may result in serious injury or death.
6. **NEVER** use tripod if you have dizzy spells, a heart condition, are afraid of heights, have been advised by a doctor or other healthcare provider not to climb, or have any condition that would impair your ability to climb up or down or use tripod as it could result in serious injury or death. Please consult a physician prior to use.
7. **DO NOT** use tripod under the influence of alcohol, medication, or any illegal substances. Using the tripod while under influence of any of these substances may result in serious injury or death.
8. **NEVER** use tripod during inclement weather. **DO NOT** use tripod during thunderstorms or any other weather conditions that included (but not limited to) lightning, freezing rain that could create slippery or dangerous conditions.
9. **DO NOT** use the tripod unless the ground is dry or level. Failure to use tripod when the ground is dry or level may result in serious injury or death.
10. **DO NOT** leave your tripod outside all year round. It must be stored inside when not in use.
11. **NEVER** climb tripod with your weapon. Make sure that the unloaded firearm gun barrel is pointed toward the ground when raising or lowering it to your stand. Always use a safe hoist/lift system on the opposite side of the tree from which you are climbing.
12. **ALWAYS** unload your weapon and use safety lock while raising or lowering your weapon. Failure to unload your weapon may result in serious injury or death.
13. **ALWAYS** have a communication device on your person and easily accessible. Immediate access to another person may save your life. In the event of an accident, a rescue plan must be in place and able to be incorporated immediately.
14. **DO NOT** fall asleep in your stand as you may potentially fall out resulting in serious injury or death.

Thank you for purchasing the Tripod Extension Kit by Primal Vantage Company Inc. The extension does require some assembly. You will find detailed instructions with your extension. The following instructions will tell you how to assemble and use your extension. Every year hunters are seriously injured in treestand accidents. Please carefully read and follow these instructions. For customer service visit www.treestandcustomerservice.com or call 1-866-972-6168 and ask for Primal Vantage.

TREESTAND SAFETY WARNINGS

Please read the following instruction manual and warnings labels completely before utilizing this tripod. Failure to understand and execute the instructions and warnings may result in serious injury or death. In the event of an accident, have a plan for rescue, including the use of devices that may be easily reached while suspended. **NEVER** hunt without a rescue plan.

ALWAYS read all warnings and instructions before each use of this tripod. Failure to read all warnings and instructions may result in serious injury or death.

DO NOT use tripod if any nuts or bolts or parts are loose, bent, or crooked.

NEVER exceed weight limit of **300 lbs.** **DO NOT** use if your combined weight with all of your hunting gear and any accessories exceeds **300 lbs.** Use of tripod over the weight limit may result in serious injury or death.

NEVER let children play with or use this tripod without adult supervision. This tripod is not a toy.

DO NOT use this tripod while under the influence of alcohol, medication or any illegal substances. Use of tripod while under the influence of any of these substances may result in serious injury or death.

NEVER use this tripod during inclement weather. **DO NOT** use tripod during thunderstorms, snowstorms, hurricanes, tornadoes or any other weather conditions that include (but not limited to) lightning, icy conditions, or high winds that could create slippery or dangerous situations.

NEVER use this tripod if you have a history of health problems such as (but not limited to) heart problems, back problems, high blood pressure, impaired vision, equilibrium impairments, are afraid of heights, have been advised by a doctor or physician not to climb. If you are not physically fit, well rested, and alert, or if you have any other physical or mental condition that would impair your ability to properly use this tripod.

NEVER use tripod if you are feeling ill, nauseous, or dizzy. Physical ailments can reduce your ability to safely install, utilize, and remove your tripod. Please consult a physician prior to use.

NEVER wear jewelry or loose fitting clothing, which can cause hazardous conditions. Clothing may be caught in your equipment and cause you to fall. You must always wear non-slip or rubber boots. Shoelaces must be tucked into your boots. Rings and necklaces **MUST NOT** be worn.

NEVER transport any of your equipment with yourself while ascending or descending the ladder. You will need to have two hands free during ascending and descending for safety. Use a haul line to pull up your firearm (unloaded, chamber opened with safety lock engaged, barrel facing towards the ground), bows, arrows, knives or any other equipment to your tripod once you have reached your desired hunting height. **ONLY** pull up hunting equipment after the tripod has been secured. Prior to descending, lower your equipment on the opposite side of the stand from which you are climbing. Make sure that the unloaded firearm's safety lock is engaged and the gun barrel is pointing towards the ground.

ALWAYS hunt with a plan and a buddy. Before you leave home, let others know your exact location, when you plan to return and who is with you.

ALWAYS carry emergency signal devices such as a cell phone, walkie-talkie, whistle, signal flare, PLD (personal location device) and flashlight with you at all times and within reach even while you are suspended in your harness. Watch for changing weather conditions. In the event of an accident, remain calm and seek help immediately.

DO NOT modify or alter your tripod. Improper installation or adjustment may cause serious injury or death. Remove all contents from box. Inspect for any damaged or missing parts. If any parts are missing or damaged, you must only use certified replacement parts. Using any other replacement parts will void product warranty. **THERE ARE NO EXTRA PARTS.** All parts **MUST** be used to ensure the safety of you and your stand. If you think parts are missing or damaged, **STOP IMMEDIATELY** and contact our Customer Service Department. Using the tripod with missing or damaged parts may result in serious injury or death. Contact a Customer Service Representative if you have any missing, damaged or extra parts.

PRACTICE installing, adjusting and using your tripod at ground level prior to using it at an elevated position.

ALWAYS step firmly on the first rung of the bottom ladder section to set the ladder into the ground before proceeding to climb the ladder.

NEVER use homemade or permanently elevated stands or make modifications to a purchased tripod.

ALWAYS have a minimum of three people present when installing or removing this tripod.

ALWAYS know your physical limitations. Don't take chances. If you start thinking about how high you are, don't go any higher. Instead, choose a minimum height that will allow for safe, effective and comfortable hunting.

NEVER use this tripod for any use other than hunting. **NEVER** lean out from the tripod for any reason. **NEVER** use this tripod for trimming trees. **NEVER** jump or bounce on the tripod's platforms or ladder sections to seat it.

NEVER fall asleep in your tripod as you may fall out resulting in serious injury or death.

NEVER adjust your tripod while in use. **ALWAYS** ensure that you and your tripod are safely secured. Your tripod **MUST** be secured in place. If the stand is not secure, it may shift while in use, resulting in serious injury or death.

ALWAYS maintain three points of contact when climbing the tripod. (Two feet, one hand **or** one foot, two hands)

Instructions should be kept in a safe place and reviewed before each use. Furnish instructions to anyone who borrows or purchases the tripod from you.

ALWAYS be sure to retighten all bolts **BEFORE** each new use of tripod. **DO NOT** leave your tripod outside. It must be stored inside when not in use.

ALWAYS inspect every ladder section connection every time you use the tripod before leaving the ground. If the ladder sections are separating, with the help of three other people remove the tripod from the tree and reinstall.

ALWAYS check the ground under the tripod to make sure it is firm and level. Sloping ground or uneven surfaces (one side of a rock or root) can cause your tripod to tilt or shift off the tree.

NEVER use this tripod with a second person. The product is designed for use by **ONE** person **ONLY**.

WARNING

DO NOT use this tripod without reading and following all warnings and instructions before each use. Failure to do so may result in serious injury or death.

ALWAYS inspect your tripod before each use and **DO NOT** use if parts are missing, worn, or damaged.

DO NOT exceed the tripod's **300 lbs.** weight limit which includes your body weight as well as the weight of your hunting gear. Exceeding the tripod's weight may cause the tripod to break or fail resulting in serious injury or death.

NEVER stand on tripod sections, rest, arms, or smooth surfaces. Standing on any of these parts may cause the tripod to break or fail resulting in serious injury or death.

NEVER make any alterations or modifications to the tripod. Doing so may result in serious injury or death and void all warranties.

NEVER use tripod during thunderstorms, snowstorms, hurricanes, tornadoes or any other weather conditions that include (but not limited to) lightning, icy conditions, or high winds that could create slippery or dangerous situations.

DO NOT use tripod if you are feeling ill, nauseous, or dizzy. Physical ailments can reduce your ability to safely install, utilize, and remove your tripod. Please consult a physician prior to use.

NEVER use this tripod if you have a history of health problems such as (but not limited to) heart problems, back problems, high blood pressure, impaired vision, equilibrium impairments, are afraid of heights, have been advised by a doctor or physician not to climb. If you are not physically fit, well rested, and alert, or if you have any other physical or mental condition that would impair your ability to properly use this tripod.

NEVER wear jewelry or loose fitting clothing, which can cause hazardous conditions. Clothing may be caught in your equipment and cause you to fall. You must always wear non-slip or rubber boots. Shoelaces must be tucked into your boots. Rings and necklaces **MUST NOT** be worn.

NEVER transport any of your equipment with yourself while ascending or descending the ladder. You will need to have two hands free during ascending and descending for safety. Use a haul line to pull up your firearm (unloaded, chamber opened with safety lock engaged, barrel facing towards the ground), bows, arrows, knives or any other equipment to your tripod once you have reached your desired hunting height. **ONLY** pull up hunting equipment after the tripod has been secured. Prior to descending, lower your equipment on the opposite side of the stand from which you are climbing. Make sure that the unloaded firearm's safety lock is engaged and the gun barrel is pointing towards the ground.

ALWAYS maintain three points of contact when climbing the tripod. (Two feet, one hand **or** one foot, two hands)

ALWAYS know your physical limitations. Don't take chances. If you start thinking about how high you are, don't go any higher. Instead, choose a minimum height that will allow for safe, effective and comfortable hunting.

NEVER use this tripod for any use other than hunting. **NEVER** lean out from the tripod for any reason. **NEVER** use this tripod for trimming trees. **NEVER** jump or bounce on the tripod's platforms or ladder sections to seat it.

NEVER fall asleep in your tripod as you may fall out resulting in serious injury or death.

NEVER adjust your tripod while in use. **ALWAYS** ensure that you and your tripod are safely secured. Your tripod **MUST** be secured in place. If the stand is not secure, it may shift while in use, resulting in serious injury or death.

ALWAYS maintain three points of contact when climbing the tripod. (Two feet, one hand **or** one foot, two hands)



NEVER remove any safety warning stickers from this product.

Safety must be your first priority during the use of this product.

Distributed by Primal Vantage Company Inc. 685 Route 10 East, Randolph, NJ 07869 www.treestandcustomerservice.com

© 2009

© 2009

SGTS-EXT Assembly Instructions Page 2

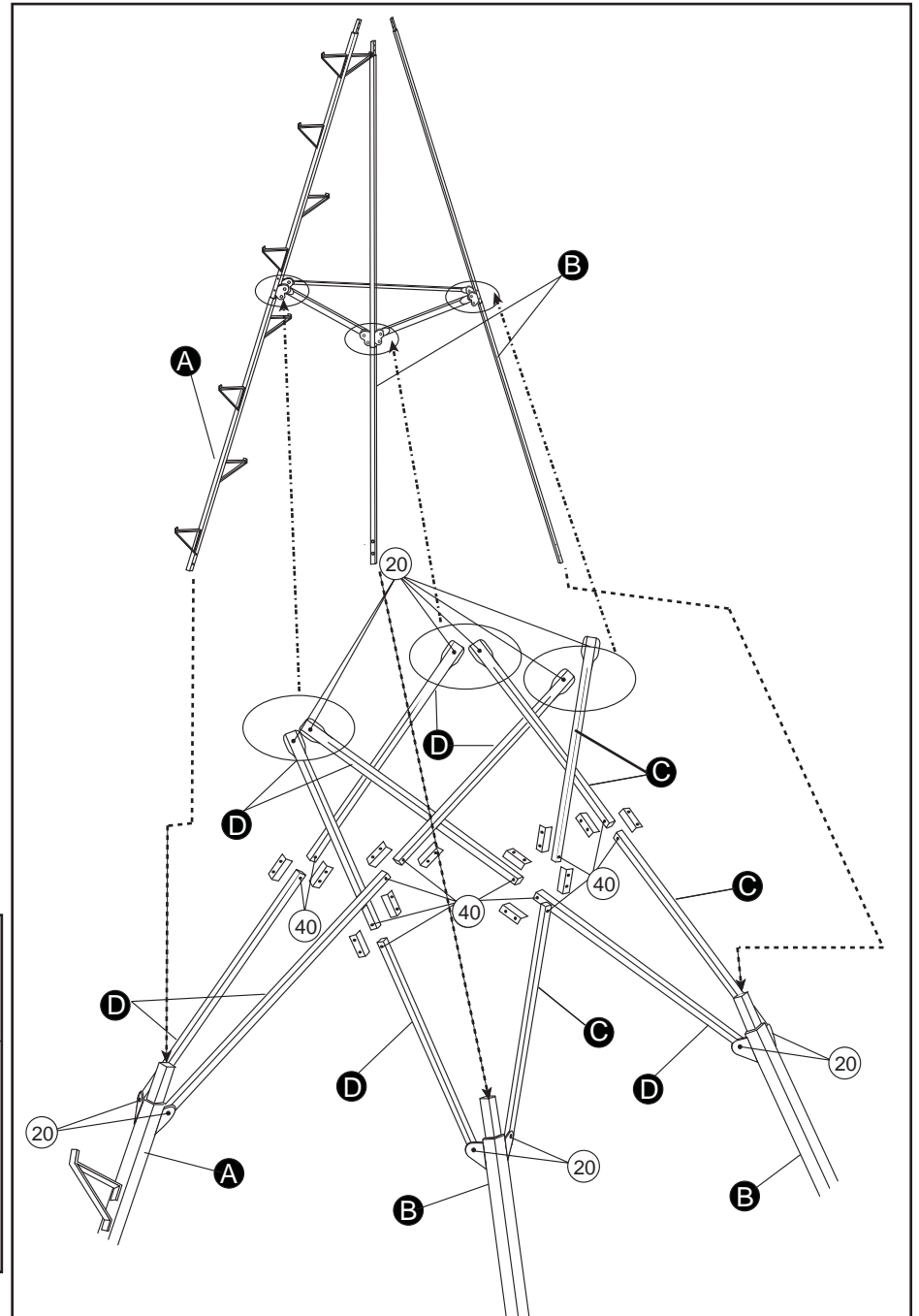
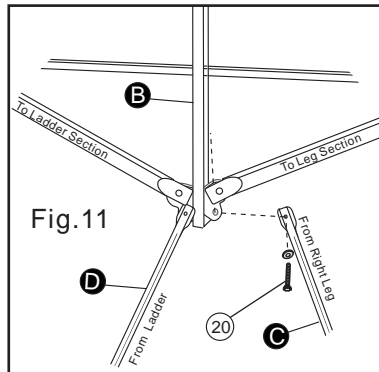
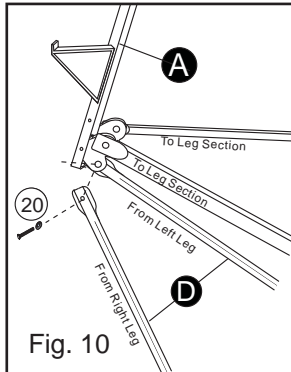
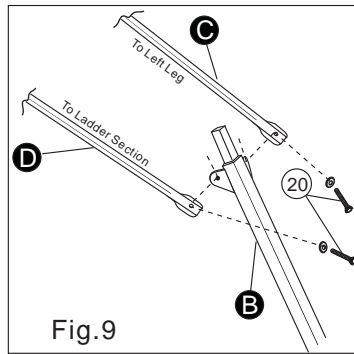
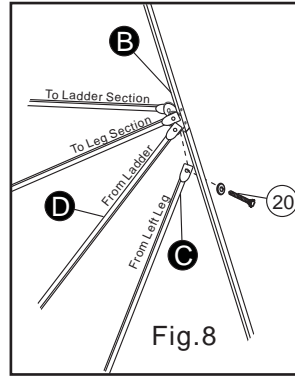
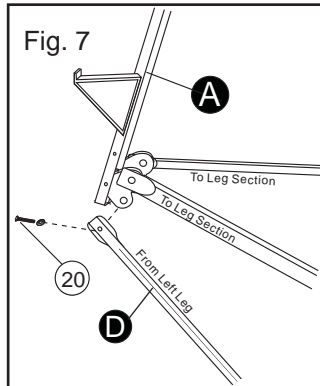
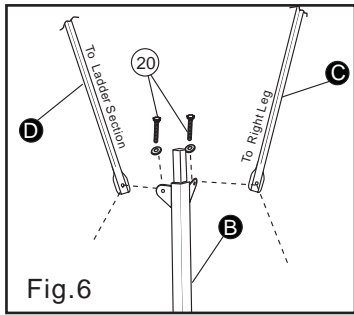
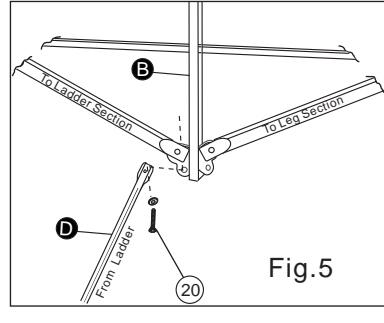
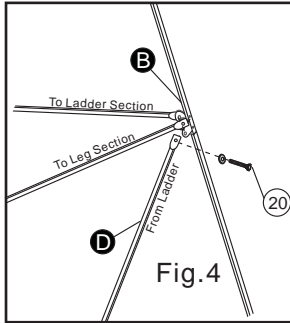
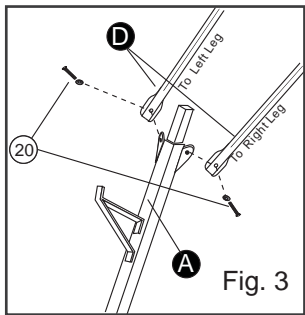
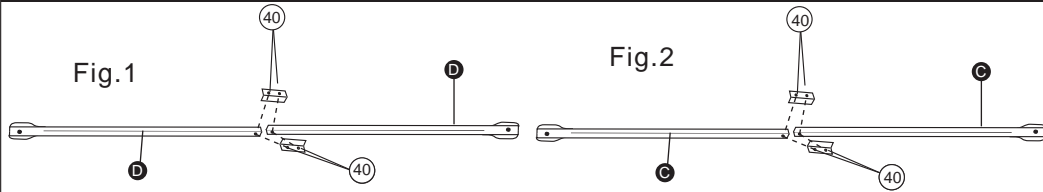

SGTS-EXT 3ft Tripod Extension Assembly

1. With the help of at least two other people lay the **SGTS-13R Tripod** on the ground. Remove the bolts holding the feet in place. Store these for use in future steps.
2. Insert the flanged end of the bottom Ladder Section **(A)** into the original ladder section. Use **2-50mm bolts** to attach the ladder sections together. (Make sure the flanges are on the inside of the tripod.)
3. Insert the flanged end of each new bottom Leg Section **(B)** in to the original legs. Use **2-50mm bolts** for each leg.
4. Insert the feet back into the new bottom sections and attach them using the bolts you removed.
5. Assemble all **(D)** Braces together using 2 Brackets **(E)** and **2-40mm bolts** for each brace assembly. (You will have four **(D)** Brace Assemblies) **(See Fig. 1)**
6. Assemble all **(C)** Braces together using 2 Brackets **(E)** and **2-40mm bolts** for each brace assembly. (You will have two **(C)** Brace Assemblies.) **(See Fig. 2)**
7. Attach two **(D)** Brace Assemblies to the Bottom Ladder Section **(A)** at the flanges using **1-20mm bolt** for each brace. **(See Fig. 3)**
8. The right one attaches to the upper right leg, bottom right hand flange. **(See Fig. 4)** The left one attaches to the upper left leg, bottom left hand flange. **(See Fig. 5)** Use **1-20mm Bolt** at each attachment point.
9. Attach one **(D)** Brace Assembly to the lower left leg on the left hand flange and one **(C)** Brace Assembly to the right hand flange using **1-20mm bolt**. **(See Fig. 6)**
10. The **(D)** Brace Assembly will attach to the upper Ladder Section at the bottom left hand flange. **(See Fig. 7)** The **(C)** Brace Assembly will attach to the upper Right Leg bottom left hand flange. Use **1-20mm bolt** for each. **(See Fig. 8)**
11. Attach one **(D)** Brace Assembly to the lower right leg on the right hand flange and one **(C)** Brace Assembly to the left hand flange. Use **1-20mm bolt** at each attachment point. **(See Fig. 9)**
12. The **(D)** Brace Assembly will attach to the upper Ladder Section at the bottom right hand flange. **(See Fig. 10)** The **(C)** Brace Assembly will attach to the upper Left Leg bottom right hand flange. Use **1-20mm bolt** for each. **(See Fig. 11)**

⚠ Warning ⚠ Warning ⚠ Warning ⚠ Warning ⚠ Warning ⚠ Warning ⚠ Warning ⚠ Warning ⚠

1. **ALWAYS** read all warnings and instructions before each use of tripod. Failure to read all warnings and instructions before each use of tripod may result in serious injury or death.
2. Remove all contents from box. Remove all cardboard from the product. Inspect for any damaged or missing pieces. **DO NOT** assemble or use tripod if any parts are missing or damaged. Using the tripod with missing or damaged parts may result in serious injury or death. Missing or damaged parts may be obtained from the address and phone number listed below.
3. **DO NOT** use tripod if any bolts or nuts are loose, bent or crooked.
4. Be sure to retighten all bolts before each new use of tripod.
5. Weight limit of this tripod is **300 lbs**. **DO NOT** use tripod if you or your combined weight with any accessories are more than **300 lbs**. Using this tripod when over **300 lbs**. may result in serious injury or death.
6. **NEVER** use tripod if you have dizzy spells, a heart condition, are afraid of heights, have been advised by a doctor or other healthcare provider not to climb, or have any condition that would impair your ability to climb up or down or use tripod as it could result in serious injury or death. Please consult a physician prior to use.
7. **DO NOT** use tripod under the influence of alcohol, medication, or any illegal substances. Using the tripod while under influence of any of these substances may result in serious injury or death.
8. **NEVER** use tripod during inclement weather. **DO NOT** use tripod during thunderstorms or any other weather conditions that included (but not limited to) lightning, freezing rain that could create slippery or dangerous conditions.
9. **DO NOT** use the tripod unless the ground is dry or level. Failure to use tripod when the ground is dry or level may result in serious injury or death.
10. **DO NOT** leave your tripod outside all year round. It must be stored inside when not in use.
11. **NEVER** climb tripod with your weapon. Make sure that the unloaded firearm gun barrel is pointed toward the ground when raising or lowering it to your stand. Always use a safe hoist/lift system on the opposite side of the tree from which you are climbing.
12. **ALWAYS** unload you weapon and use safety lock while raising or lowering your weapon. Failure to unload your weapon may result in serious injury or death.
13. **ALWAYS** have a communication device on your person and easily accessible. Immediate access to another person may save your life. In the event of an accident, a rescue plan must be in place and able to be incorporated immediately.
14. **DO NOT** fall asleep in your stand as you may potentially fall out resulting in serious injury or death.

! W A R N I N G

DO NOT use this tripod without reading and following all warnings and instructions before each use. Failure to do so may result in serious injury or death.

ALWAYS inspect your tripod before each use and **DO NOT** use if parts are missing, worn, or damaged.

DO NOT exceed the tripod's **300 lbs.** weight limit, which includes your body weight as well as the weight of your clothes and gear. Exceeding the tripod's weight limit may cause the tripod to break or fail resulting in serious injury or death.

NEVER stand on tripod seat, footrest, armrest, or shooting rail. Standing on any of these parts may cause the tripod to break or fail resulting in serious injury or death.

NEVER make any alterations or modifications to the tripod. Doing so may result in serious injury or death and void all warranties.

NEVER use tripod during inclement weather. **DO NOT** use tripod during thunderstorms or any other weather conditions that include (but not limited to) lightning, freezing rain, high winds that could create slippery or dangerous conditions.

DO NOT use this tripod under the influence of alcohol, illegal substances or medication. Using tripod under the influence of alcohol, illegal substances or medication may result in serious injury or death.

NEVER use tripod if you have dizzy spells, a heart problem, are afraid of heights, have been advised by a doctor or other health care provider not to climb, or have any condition that would impair your ability to climb up or down or use tripod as it could result in serious injury or death.

NEVER remove or deface tripod warning labels. Replacement labels can be obtained from the address below.

