

Model: SGTS-EXT

# 3Ft Tripod Extension

- Weight Limit **300 lbs.**
- Do Not Over Tighten Fasteners

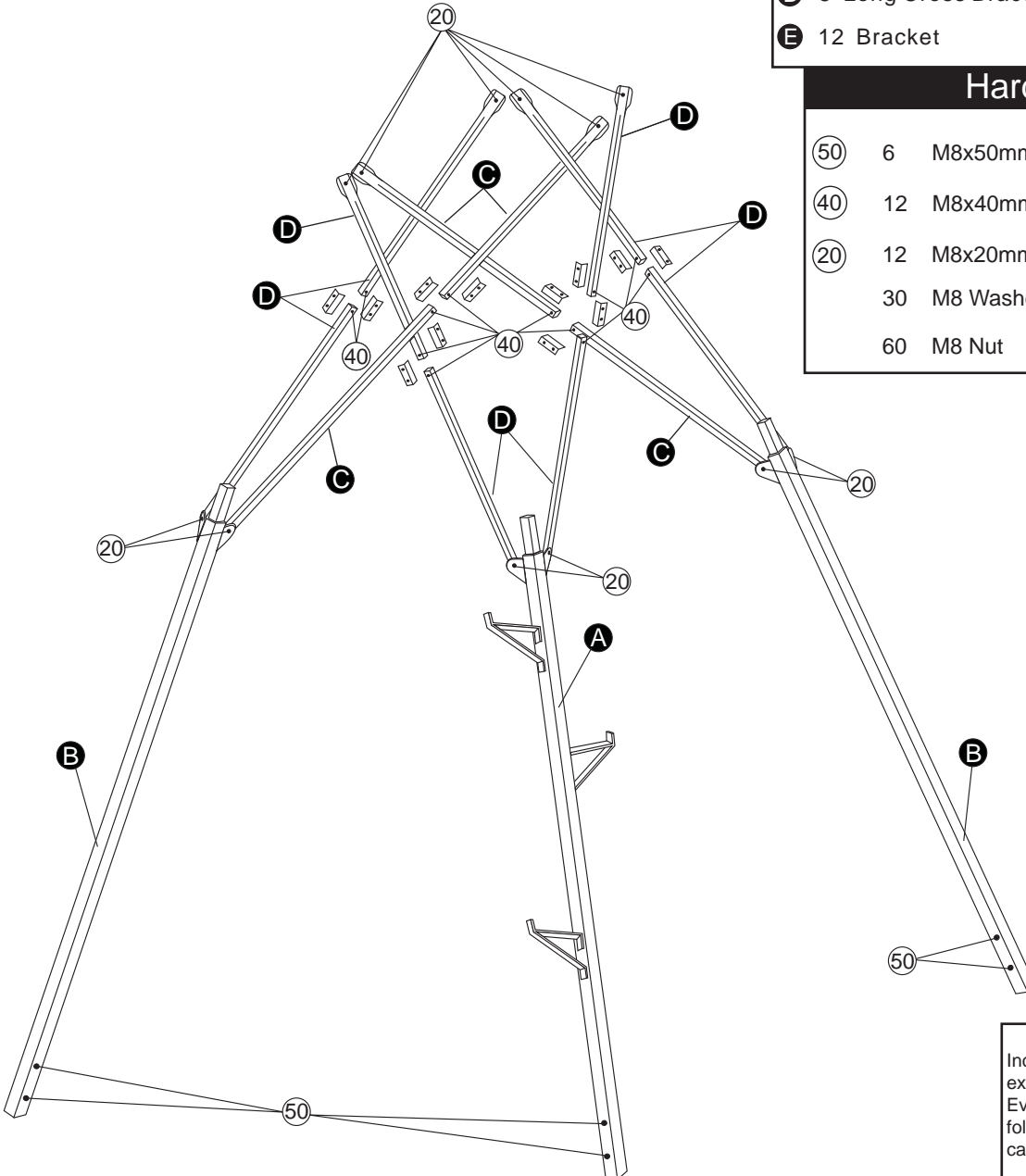

## Parts List

<b>A</b>	1 Bottom Ladder Section	Part # GL-300
<b>B</b>	2 Bottom Leg	Part # GL-350
<b>C</b>	4 Short Cross Brace 41.5"	Part # GCB-300
<b>D</b>	8 Long Cross Brace 47.1"	Part # GCB-350
<b>E</b>	12 Bracket	Part # GB-300

## Hardware

50	6	M8x50mm Bolt	Part # 1850
40	12	M8x40mm Bolt	Part # 1840
20	12	M8x20mm Bolt	Part # 1820
	30	M8 Washer	Part # 1800
	60	M8 Nut	Part # 1810

⚠ Warning ⚠ Warning ⚠ Warning ⚠ Warning ⚠ Warning

1. **ALWAYS** read all warnings and instructions before each use of tripod. Failure to read all warnings and instructions before each use of tripod may result in serious injury or death.
2. Remove all contents from box. Remove all cardboard from the product. Inspect for any damaged or missing pieces. **DO NOT** assemble or use tripod if any parts are missing or damaged. Using the tripod with missing or damaged parts may result in serious injury or death. Missing or damaged parts may be obtained from the address and phone number listed below.
3. **DO NOT** use tripod if any bolts or nuts are loose, bent or crooked.
4. Be sure to retighten all bolts before each new use of tripod.
5. Weight limit of this tripod is **300 lbs.** **DO NOT** use tripod if you or your combined weight with any accessories are more than **300 lbs.** Using this tripod when over **300 lbs.** may result in serious injury or death.
6. **NEVER** use tripod if you have dizzy spells, a heart condition, are afraid of heights, have been advised by a doctor or other healthcare provider not to climb, or have any condition that would impair your ability to climb up or down or use tripod as it could result in serious injury or death. Please consult a physician prior to use.
7. **DO NOT** use tripod under the influence of alcohol, medication, or any illegal substances. Using the tripod while under influence of any of these substances may result in serious injury or death.
8. **NEVER** use tripod during inclement weather. **DO NOT** use tripod during thunderstorms or any other weather conditions that included (but not limited to) lightning, freezing rain that could create slippery or dangerous conditions.
9. **DO NOT** use the tripod unless the ground is dry or level. Failure to use tripod when the ground is dry or level may result in serious injury or death.
10. **DO NOT** leave your tripod outside all year round. It must be stored inside when not in use.
11. **NEVER** climb tripod with your weapon. Make sure that the unloaded firearm gun barrel is pointed toward the ground when raising or lowering it to your stand. Always use a safe hoist/lift system on the opposite side of the tree from which you are climbing.
12. **ALWAYS** unload your weapon and use safety lock while raising or lowering your weapon. Failure to unload your weapon may result in serious injury or death.
13. **ALWAYS** have a communication device on your person and easily accessible. Immediate access to another person may save your life. In the event of an accident, a rescue plan must be in place and able to be incorporated immediately.
14. **DO NOT** fall asleep in your stand as you may potentially fall out resulting in serious injury or death.

Thank you for purchasing the Tripod Extension Kit by Primal Vantage Company Inc. The extension does require some assembly. You will find detailed instructions with your extension. The following instructions will tell you how to assemble and use your extension. Every year hunters are seriously injured in treestand accidents. Please carefully read and follow these instructions. For customer service visit [www.treestandcustomerservice.com](http://www.treestandcustomerservice.com) or call 1-800-722-7345 and ask for Primal Vantage.

## TREESTAND SAFETY WARNINGS

Please read the following instruction manual and warnings labels completely before utilizing this tree stand. Failure to understand and execute the instructions and warnings may result in serious injury or death. In the event of an accident, have a plan for rescue, including the use of devices that may be easily reached while suspended. **NEVER** hunt without a rescue plan.

**ALWAYS** read all warnings and instructions before each use of this tree stand. Failure to read all warnings and instructions may result in serious injury or death.

**ALWAYS** wear a Fall Arrest System (FAS) (Harness) after leaving the ground. Failure to wear your Fall Arrest System (Harness) may result in serious injury or death.

**ALWAYS** use a Full Body Safety Harness when using this tree stand. This tree stand includes a TMA Certified Full Body Harness. The TMA Certified Full Body Harness must always be connected to yourself and the tree during ascending, hunting and descending. Falls can occur at anytime after leaving the ground.

**ALWAYS** inspect the tree stand and the **Fall Arrest System** (Harness) for signs of wear or damage **BEFORE** each use. Also inspect to ensure that nuts and bolts are secure. Pay special attention to the harness and straps, guaranteeing that nothing has been frayed or severed. Destroy all products that cannot be repaired by the manufacturer. Contact a Customer Service Representative for replacement parts. The Fall Arrest System **MUST** be discarded and replaced after a fall has occurred.

**DO NOT** use tree stand if any nuts or bolts or parts are loose, bent, or crooked.

**NEVER** exceed weight limit of **300 lbs.** **DO NOT** use if your combined weight with all of your hunting gear and any accessories exceeds **300 lbs.** Use of tree stand over the weight limit may result in serious injury or death.

**NEVER** let children play with or use this tree stand without adult supervision. This tree stand is not a toy.

**DO NOT** use this tree stand while under the influence of alcohol, medication or any illegal substances. Use of tree stand while under the influence of any of these substances may result in serious injury or death.

**NEVER** use this tree stand during inclement weather. **DO NOT** use tree stand during thunderstorms, snowstorms, hurricanes, tornadoes or any other weather conditions that include (but not limited to) lightning, icy conditions, or high winds that could create slippery or dangerous situations.

**NEVER** use this tree stand if you have a history of health problems such as (but not limited to) heart problems, back problems, high blood pressure, impaired vision, equilibrium impairments, are afraid of heights, have been advised by a doctor or physician not to climb. If you are not physically fit, well rested, and alert, or if you have any other physical or mental condition that would impair your ability to properly use this tree stand.

**NEVER** use tree stand if you are feeling ill, nauseous, or dizzy. Physical ailments can reduce your ability to safely install, utilize, and remove your tree stand. Please consult a physician prior to use.

**NEVER** wear jewelry or loose fitting clothing, which can cause hazardous conditions. Clothing may be caught in your equipment and cause you to fall. You must always wear non-slip or rubber boots. Shoelaces must be tucked into your boots. Rings and necklaces **MUST NOT** be worn.

**NEVER** use this tree stand on a tree that is dead, leaning, diseased, loose barked or on a utility pole as the tree may fall, break, or uproot and may result in serious injury or death.

**NEVER** transport any of your equipment with yourself while ascending or descending the tree. You will need to have two hands free during ascending and descending for safety. Use a haul line to pull up your firearm (unloaded, chamber opened with safety lock engaged, barrel facing towards the ground), bows, arrows, knives or any other equipment to your tree stand once you have reached your desired hunting height. **ONLY** pull up hunting equipment after the tree stand has been secured to the tree and after you and your harness have been secured to the tree. Prior to descending, lower your equipment on the opposite side of the tree from which you are climbing. Make sure that the unloaded firearm's safety lock is engaged and the gun barrel is pointing towards the ground.

**ALWAYS** hunt with a plan and a buddy. Before you leave home, let others know your exact location, when you plan to return and who is with you.

**ALWAYS** attach your Full Body Harness in the manner and method described by the manufacturer. Beware of hazards associated with Full Body Harnesses and the fact that prolonged suspension in a harness may be fatal. Have in place a plan for rescue, including the use of cell phones, or signal devices that may be easily reached while suspended. If rescue personnel cannot be notified, you must have a plan for recover/escape. If you have to hang suspended for a period of time before help arrives, exercise your legs by pushing against the tree or doing any other form of continuous motion. Failure to recover in a timely manner could result in serious injury or death. If you do not have the ability to recover/escape, hunt from the ground.

**ALWAYS** carry emergency signal devices such as a cell phone, walkie-talkie, whistle, signal flare, PLD (personal location device) and flashlight with you at all times and within reach even while you are suspended in your harness. Watch for changing weather conditions. In the event of an accident, remain calm and seek help immediately.

**DO NOT** modify or alter your tree stand. Improper installation or adjustment may cause serious injury or death. Remove all contents from box. Inspect for any damaged or missing parts. If any parts are missing or damaged, you must only use certified replacement parts. Using any other replacement parts will void product warranty. **THERE ARE NO EXTRA PARTS.** All parts **MUST** be used to ensure the safety of you and your stand. If you think parts are missing or damaged, **STOP IMMEDIATELY** and contact our Customer Service Department. Using the tree stand with missing or damaged parts may result in serious injury or death. Contact a Customer Service Representative if you have any missing, damaged or extra parts.



# SGTS-EXT Assembly Instructions Page 2

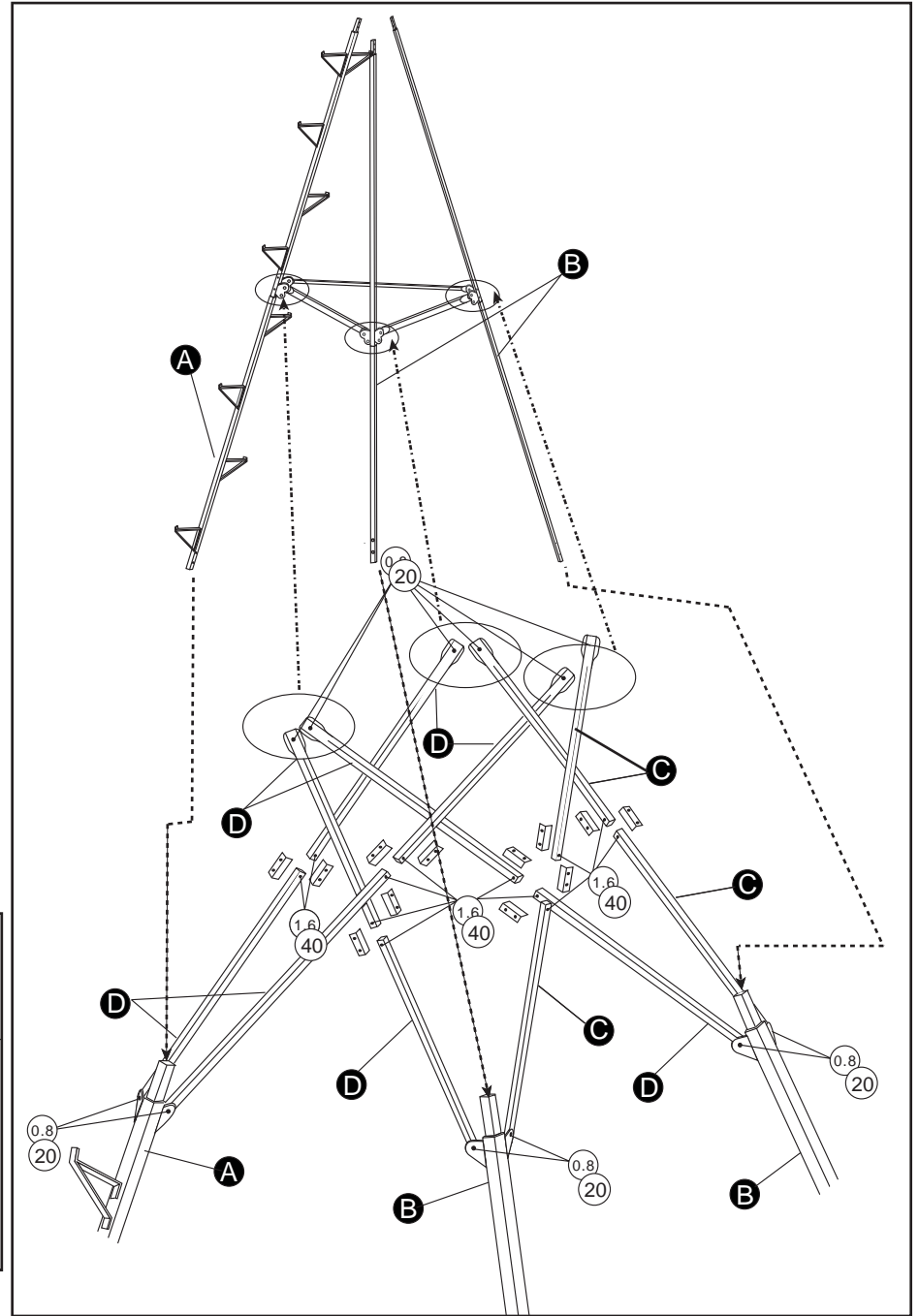
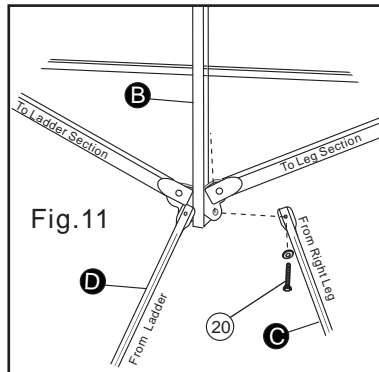
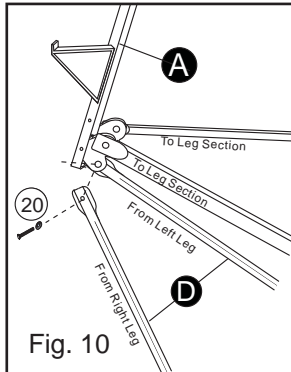
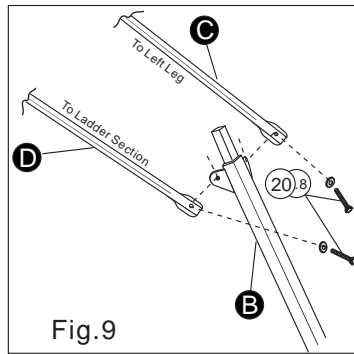
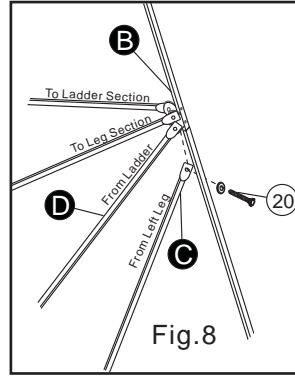
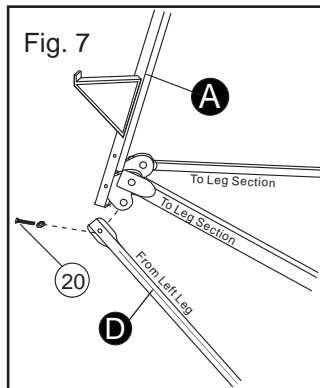
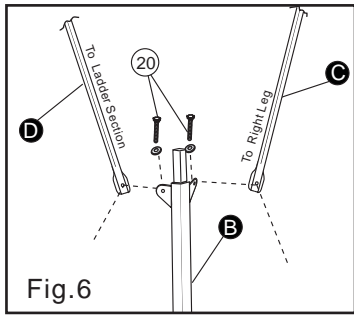
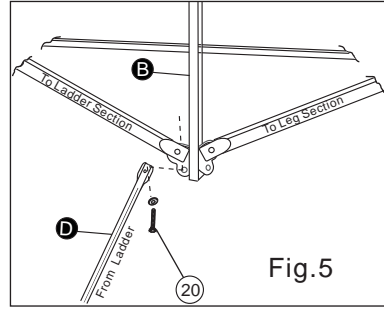
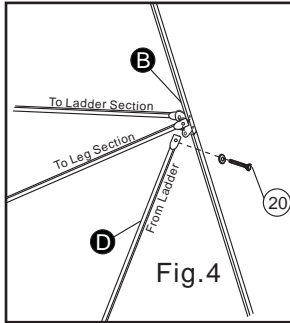
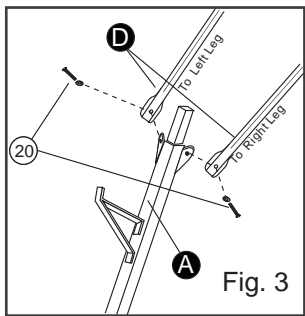
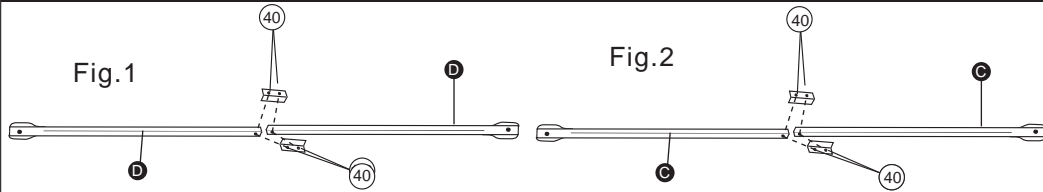

## SGTS-EXT 3ft Tripod Extension Assembly

1. With the help of at least two other people lay the **SGTS-13R Tripod** on the ground. Remove the bolts holding the feet in place. Store these for use in future steps.
2. Insert the flanged end of the bottom Ladder Section **(A)** into the original ladder section. Use **2-50mm bolts** to attach the ladder sections together. (Make sure the flanges are on the inside of the tripod.)
3. Insert the flanged end of each new bottom Leg Section **(B)** in to the original legs. Use **2-50mm bolts** for each leg.
4. Insert the feet back into the new bottom sections and attach them using the bolts you removed.
5. Assemble all **(D)** Braces together using 2 Brackets **(E)** and **2-40mm bolts** for each brace assembly. (You will have four **(D)** Brace Assemblies) **(See Fig. 1)**
6. Assemble all **(C)** Braces together using 2 Brackets **(E)** and **2-40mm bolts** for each brace assembly. (You will have two **(C)** Brace Assemblies.) **(See Fig. 2)**
7. Attach two **(D)** Brace Assemblies to the Bottom Ladder Section **(A)** at the flanges using **1-20mm bolt** for each brace. **(See Fig. 3)**
8. The right one attaches to the upper right leg, bottom right hand flange. **(See Fig. 4)** The left one attaches to the upper left leg, bottom left hand flange. **(See Fig. 5)** Use **1-20mm Bolt** at each attachment point.
9. Attach one **(D)** Brace Assembly to the lower left leg on the left hand flange and one **(C)** Brace Assembly to the right hand flange using **1-20mm bolt**. **(See Fig. 6)**
10. The **(D)** Brace Assembly will attach to the upper Ladder Section at the bottom left hand flange. **(See Fig. 7)** The **(C)** Brace Assembly will attach to the upper Right Leg bottom left hand flange. Use **1-20mm bolt** for each. **(See Fig. 8)**
11. Attach one **(D)** Brace Assembly to the lower right leg on the right hand flange and one **(C)** Brace Assembly to the left hand flange. Use **1-20mm bolt** at each attachment point. **(See Fig. 9)**
12. The **(D)** Brace Assembly will attach to the upper Ladder Section at the bottom right hand flange. **(See Fig. 10)** The **(C)** Brace Assembly will attach to the upper Left Leg bottom right hand flange. Use **1-20mm bolt** for each. **(See Fig. 11)**

### Warning Warning Warning Warning Warning Warning Warning Warning

1. **ALWAYS** read all warnings and instructions before each use of tripod. Failure to read all warnings and instructions before each use of tripod may result in serious injury or death.
2. Remove all contents from box. Remove all cardboard from the product. Inspect for any damaged or missing pieces. **DO NOT** assemble or use tripod if any parts are missing or damaged. Using the tripod with missing or damaged parts may result in serious injury or death. Missing or damaged parts may be obtained from the address and phone number listed below.
3. **DO NOT** use tripod if any bolts or nuts are loose, bent or crooked.
4. Be sure to retighten all bolts before each new use of tripod.
5. Weight limit of this tripod is **300 lbs**. **DO NOT** use tripod if you or your combined weight with any accessories are more than **300 lbs**. Using this tripod when over **300 lbs**. may result in serious injury or death.
6. **NEVER** use tripod if you have dizzy spells, a heart condition, are afraid of heights, have been advised by a doctor or other healthcare provider not to climb, or have any condition that would impair your ability to climb up or down or use tripod as it could result in serious injury or death. Please consult a physician prior to use.
7. **DO NOT** use tripod under the influence of alcohol, medication, or any illegal substances. Using the tripod while under influence of any of these substances may result in serious injury or death.
8. **NEVER** use tripod during inclement weather. **DO NOT** use tripod during thunderstorms or any other weather conditions that included (but not limited to) lightning, freezing rain that could create slippery or dangerous conditions.
9. **DO NOT** use the tripod unless the ground is dry or level. Failure to use tripod when the ground is dry or level may result in serious injury or death.
10. **DO NOT** leave your tripod outside all year round. It must be stored inside when not in use.
11. **NEVER** climb tripod with your weapon. Make sure that the unloaded firearm gun barrel is pointed toward the ground when raising or lowering it to your stand. Always use a safe hoist/lift system on the opposite side of the tree from which you are climbing.
12. **ALWAYS** unload you weapon and use safety lock while raising or lowering your weapon. Failure to unload your weapon may result in serious injury or death.
13. **ALWAYS** have a communication device on your person and easily accessible. Immediate access to another person may save your life. In the event of an accident, a rescue plan must be in place and able to be incorporated immediately.
14. **DO NOT** fall asleep in your stand as you may potentially fall out resulting in serious injury or death.