

MODEL: HEH00500
16' Climbing Stick

- Always Wear a Safety Harness with this Product
- Practice Using at Ground Level
- Weight Limit: 300 lbs.
- Tree Size: 9"-18" diameter



FIELD & STREAM™

THANK YOU! for purchasing the 16' Climbing Stick by Primal Vantage Company Inc.

⚠ Warning

Every year serious injury and even death occurs from hunting related falls. To ensure your safety, please **COMPLETELY** read and follow this safety manual and ALL warning labels **BEFORE** assembling, installing or utilizing this product.

DO NOT USE THIS PRODUCT BEFORE FULLY UNDERSTANDING ALL SAFETY WARNINGS AND INSTRUCTIONS. IF YOU HAVE QUESTIONS, ARE UNSURE ABOUT ANY INFORMATION OR NEED ADDITIONAL INFORMATION CONCERNING YOUR PRODUCT, CONTACT OUR CUSTOMER SERVICE DEPARTMENT AT 1-800-722-7345 OR VISIT WWW.TREESTANDCUSTOMERSERVICE.COM. KEEP AND MAINTAIN THIS SAFETY AND INSTRUCTION MANUAL IN A SAFE LOCATION FOR FUTURE REFERENCE.

TREESTAND SAFETY WARNINGS

Please read the following instruction manual and warnings labels completely before utilizing this product. Failure to understand and execute the instructions and warnings may result in serious injury or death. In the event of an accident, have a plan for rescue, including the use of devices that may be easily reached while suspended.

ALWAYS read and understand all warnings and instructions and use all safety products provided before each use of this product. Failure to read and understand all warnings and instructions may result in serious injury or death. Contact a Customer Service Representative with any questions you may have.

NEVER exceed weight limit of **300 lbs.** **DO NOT** use if your combined weight with all of your hunting gear and any accessories exceeds **300 lbs.** Use of tree stand over the weight limit may result in serious injury or death.

ALWAYS wear a Fall Arrest System (FAS) (Harness) consisting of a full body safety harness with lineman's belt after leaving the ground. You **MUST** stay connected at all times after leaving the ground while using climbing aids, hang-ons and climbing tree stands. Single safety belts and chest harnesses are no longer preferred and should **NEVER** be used. If you are not wearing a Fall Arrest System (FAS) that is protecting you from a fall, **DO NOT leave the ground.** Failure to wear your Fall Arrest System (FAS) (Harness) may result in serious injury or death. Falls can occur at anytime after leaving the ground.

ALWAYS use a Full Body Safety Harness when using this tree stand. A TMA Certified Full Body Harness with lineman's belt must always be connected to yourself and the tree during ascending, hunting and descending. The use of a lineman's belt is **REQUIRED AT ALL TIMES** during ascending, hunting and descending the tree stand. When using a lineman's belt to ascend the tree, the full body harness **MUST** be attached to the tree before stepping onto the tree stand. The length of the harness tether strap must be minimized at all times. It should be adjusted so that it is above the head with no slack in the sitting position and you should have the minimum amount of slack possible when climbing.

ALWAYS inspect the tree stand and the Fall Arrest System (FAS) (Harness) for signs of wear or damage **BEFORE** each use. Also inspect to ensure that nuts and bolts are secure. Pay special attention to the harness and straps, guaranteeing that nothing has been frayed or severed. Destroy all products that cannot be repaired by the manufacturer. Contact a Customer Service Representative for replacement parts. The Fall Arrest System **MUST** be discarded and replaced after a fall has occurred.

ALWAYS read and understand the manufacturer's warnings and instructions on how to use and properly adjust the harness. Attach your Full Body Harness in the manner and method described by the manufacturer. Beware of hazards associated with Full Body Harnesses and the fact that prolonged suspension in a harness may be fatal. Have in place a plan for rescue, including the use of cell phones, or signal devices that may be easily reached while suspended. If rescue personnel cannot be notified, you must have a plan for recover/escape. If you have to hang suspended for a period of time before help arrives, exercise your legs by pushing against the tree or doing any other form of continuous motion. Failure to recover in a timely manner could result in serious injury or death. If you do not have the ability to recover/escape, hunt from the ground.

DO NOT use tree stand if any nuts or bolts or parts are loose, bent, or crooked.

NEVER let children play with or use this treestand without adult supervision. This treestand is not a toy.

DO NOT use this tree stand while under the influence of alcohol, medication or any illegal substances. Use of tree stand while under the influence of any of these substances may result in serious injury or death.

NEVER use this treestand during inclement weather. **DO NOT** use tree stand during thunderstorms, snowstorms, hurricanes, tornadoes or any other weather conditions that include (but not limited to) lightning, icy conditions, or high winds that could create slippery or dangerous situations.

NEVER use this tree stand if you have a history of health problems such as (but not limited to) heart problems, back problems, high blood pressure, impaired vision, equilibrium impairments, are afraid of heights, have been advised by a doctor or physician not to climb. If you are not physically fit, well rested, and alert, or if you have any other physical or mental condition that would impair your ability to properly use this treestand.

NEVER use treestand if you are feeling ill, nauseous, or dizzy. Physical ailments can reduce your ability to safely install, utilize, and remove your treestand. Please consult a physician prior to use.

NEVER wear jewelry or loose fitting clothing, which can cause hazardous conditions. Clothing may be caught in your equipment and cause you to fall. You must always wear non-slip or rubber boots. Shoelaces must be tucked into your boots. Rings and necklaces **MUST NOT** be worn.

NEVER use this tree stand on a tree that is dead, leaning, diseased, loose barked or on a utility pole as the tree may fall, break, or uproot and may result in serious injury or death.

NEVER transport any of your equipment with yourself while ascending or descending the tree. You will need to have two hands free during ascending and descending for safety. Use a haul line to pull up your firearm (unloaded, chamber opened with safety lock engaged, barrel facing towards the ground), bows, arrows, knives or any other equipment to your tree stand once you have reached your desired hunting height. **ONLY** pull up hunting equipment after the tree stand has been secured to the tree and after you and your harness have been secured to the tree. Prior to descending, lower your equipment on the opposite side of the tree from which you are climbing. Make sure that the unloaded firearm's safety lock is engaged and the gun barrel is pointing towards the ground.

ALWAYS hunt with a plan and a buddy. Before you leave home, let others know your exact location, when you plan to return and who is with you.

ALWAYS carry emergency signal devices such as a cell phone, walkie-talkie, whistle, signal flare, PLD (personal location device) and flashlight with you at all times and within reach even while you are suspended in your harness. Watch for changing weather conditions. In the event of an accident, remain calm and seek help immediately.

DO NOT modify or alter your tree stand. Improper installation or adjustment may cause serious injury or death. Remove all contents from box. Inspect for any damaged or missing parts. If any parts are missing or damaged, you must only use certified replacement parts. Using any other replacement parts will void product warranty. **THERE ARE NO EXTRA PARTS.** All parts **MUST** be used to ensure the safety of you and your stand. If you think parts are missing or damaged, **STOP IMMEDIATELY** and contact our Customer Service Department. Using the tree stand with missing or damaged parts may result in serious injury or death. Contact a Customer Service Representative if you have any missing, damaged or extra parts.

TREESTAND SAFETY WARNINGS

PRACTICE installing, adjusting and using your tree stand at ground level prior to using it at an elevated position.

ALWAYS check the ground under the ladder stand to make sure the ground is firm and level. Sloping ground or uneven surfaces (one side of a rock or root) can cause your ladder stand to tilt or shift off the tree.

ALWAYS step firmly on the first rung of the bottom ladder section to set the ladder into the ground before proceeding to climb the ladder.

ALWAYS have a minimum of three people present when installing or removing this treestand.

NEVER use this treestand with a second person. The treestand is designed for use by **ONE** person.

ALWAYS know your physical limitations. Don't take chances. If you start thinking about how high you are, don't go any higher. Instead, choose a minimum height that will allow for safe, effective and comfortable hunting.

NEVER use this treestand for any use other than hunting. Our treestands are designed for hunter's to wear a Full Body Harness. If you are not completely comfortable and confident with your ability to safely install, ascend, hunt and descend using a Full Body Safety Harness and this treestand, **DO NOT PROCEED**.

ALWAYS lean **forward towards the tree** as you climb. **NEVER** lean out from the treestand for any reason.

NEVER use this treestand for trimming trees.

NEVER rely on a branch for support.

NEVER jump or bounce on the treestand's platform or ladder sections to seat it to the tree.

NEVER fall asleep in your stand as you may fall out resulting in serious injury or death.

NEVER adjust your stand while in use. **ALWAYS** ensure that you and your treestand are safely secured to a healthy tree. Your tree stand **MUST** be attached tightly to the tree and secured in place. If the stand is not secure, it may shift while in use, resulting in serious injury or death.

MAINTAIN three points of contact when climbing the tree stand. (Two feet, one hand or two hands, one foot).

Instructions should be kept in a safe place and reviewed before each use. Furnish instructions to anyone who borrows or purchases the treestand from you.

ALWAYS be sure to retighten all bolts **BEFORE** each new use of treestand.

DO NOT leave your treestand outside. It must be stored inside when not in use.

DO NOT carry the stand when ascending or descending the tree. Use a haul line to raise and lower your stand.

Climbing aids such as stick ladders, sectional ladders, steps or such **MUST** extend above the platform of the hang-on to allow the user to step down on the platform. **NEVER** step up to the platform. When using a climbing belt to ascend the tree, the Full Body Harness should be attached to the tree before stepping down into the treestand.

NEVER leave the ground without checking every ladder section connection. If ladder sections are separating, with the help of three other people, remove the ladder stand from the tree, tighten all connections and reinstall onto the tree.

Read and understand manufacturer's warnings, expiration date (if applicable) and instructions on how to properly adjust the harness.

PRACTICE using the Full Body Safety Harness at ground level in the presence of a responsible adult to experience the feeling of hanging suspended before using in a hunting environment.

There is time to make a correct decision on what action to take if a fall occurs while wearing a Full Body Harness. It is important to remember do not panic.

**NEVER remove any safety warning stickers from this product.
Safety must be your first priority during the use of this product.**

WARNING

ALWAYS read and understand all warnings and instructions before each use of this product. Failure to read and understand all warnings and instructions may result in serious injury or death.

ALWAYS inspect the tree stand for signs of wear or damage **BEFORE** each use. Also inspect to ensure that nuts and bolts are secure and straps are not frayed, worn, or broken.

NEVER exceed weight limit of **300 lbs.** **DO NOT** use if your combined weight with all your hunting gear and any accessories exceeds **300 lbs.** Use of tree stand over the weight limit may result in serious injury or death.

ALWAYS wear a Fall Arrest System (FAS) consisting of a full body harness, a climbing helmet, and a climbing rope. Stay connected at all times. Do not wear an FAS while on the ground.

DO NOT use this tree stand while under the influence of alcohol, medication, or any substances. Use of tree stand while under the influence of any of these substances may result in serious injury or death.

NEVER use this tree stand if you have a history of health problems such as (but not limited to) heart problems, back problems, impaired vision, equilibrium impairments are afraid of heights or have been advised by a doctor not to do any strenuous activity. If you are feeling ill, nauseous, or dizzy **DO NOT** use this tree stand or if you are not physically fit, well rested and alert.

NEVER use this tree stand in inclement weather (but not limited to) rain, snow, sleet, or ice. High winds may create a dangerous situation.

NEVER lean against or on the tree stand, leaning against a barked tree or on a utility pole may cause the stand to break, or fall and may result in serious injury.

NEVER use the ground without checking every ladder section connection to ensure they are firmly connected. If ladder sections are separating, with the help of at least two other people, remove the tree stand from the tree, tighten all connections and reinstall on the tree.

NEVER step up to the platform of the treestand. Climbing aids such as stick ladders, **MUST** extend above the platform of the hang-on to allow the user to step down on the platform. The Full Body Harness should be attached to the tree before stepping down into the treestand.

DO NOT modify or alter your tree stand.

DO NOT remove or deface any warning labels.

SAMPLE

FIELD & STREAMSM

Manufactured in the year XXXX

Primal Vantage Company Inc. 685 Route 10 East, Randolph, NJ 07869 1-800-722-7345 Contact for replacement labels

MODEL: HEH00500
16' Climbing Stick

- Always Wear a Safety Harness with this Product
- Practice Using at Ground Level
- Weight Limit: 300 lbs.
- Tree Size: 9"-18" diameter

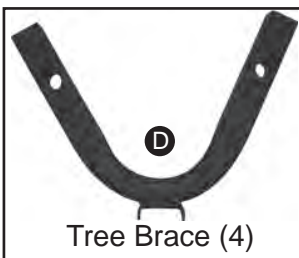

Hardware Blister Pack

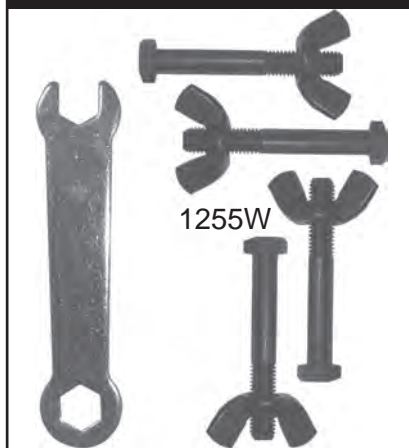

Hardware is layed out as found in blister pack

Parts List

A	1 Top Section	Part # DL-1000
B	2 Middle Section	Part # DL-1250
C	1 Bottom Section	Part # DL-1500
D	4 Tree Brace	Part # DTB-100
E	4 Buckle Strap Assy	Part # DBA-100
(55)	4 M12x55mm Bolt w/wingnut	Part # 1255W
	3 M10 Quickclips	Part # 1615

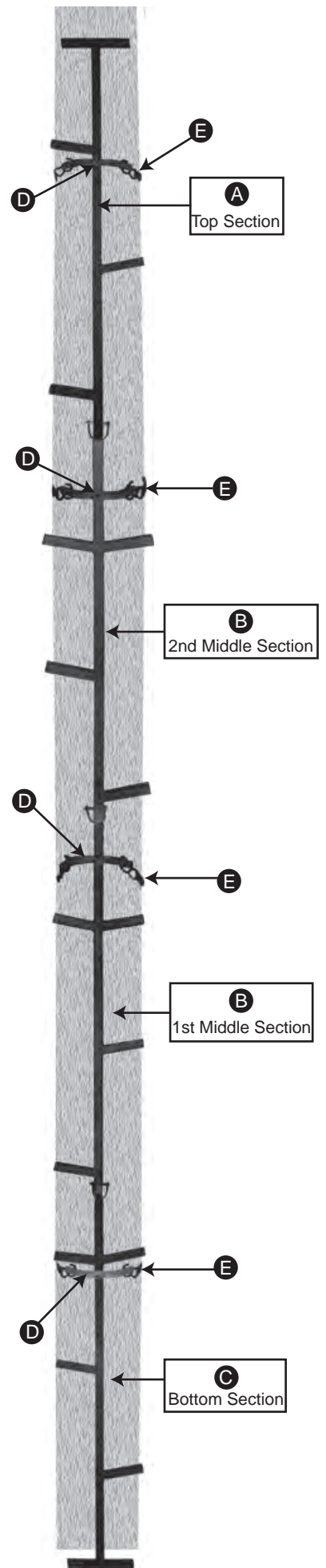

FIELD & STREAM™

Assembly Instructions

MODEL: HEH00500
16' Climbing Stick

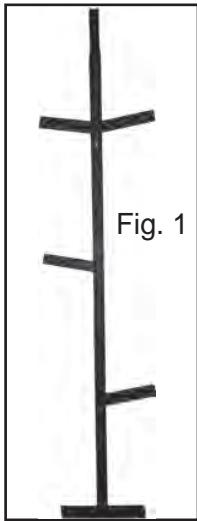

Fig. 1

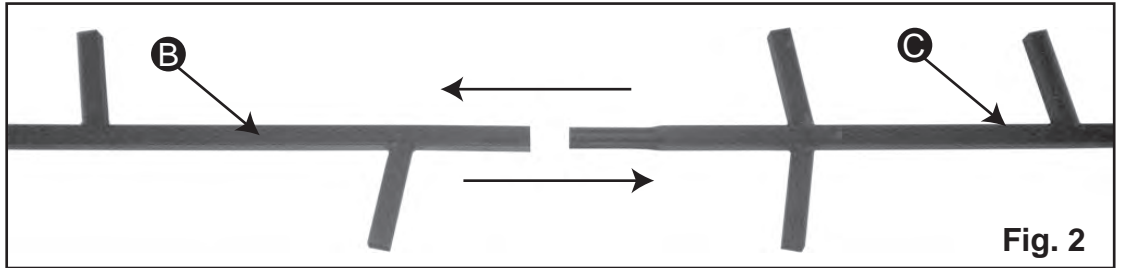

Fig. 2

2. The first step of Middle Section **B** should be facing the left hand side. Insert the male end of Bottom Section **C** into the female end of Middle Section **B**. (**Fig. 2**) Insert one quickclip through each section at the insertion point. (**Fig. 3**)

1. Lay Bottom Section **C** on the ground with the first step on the left hand side. (**Fig. 1**).

During assembly, the Top Section and the 1st Middle Section will have the first step facing the right hand side.

The Bottom section and the 2nd Middle Section will have the first step facing the left hand side.

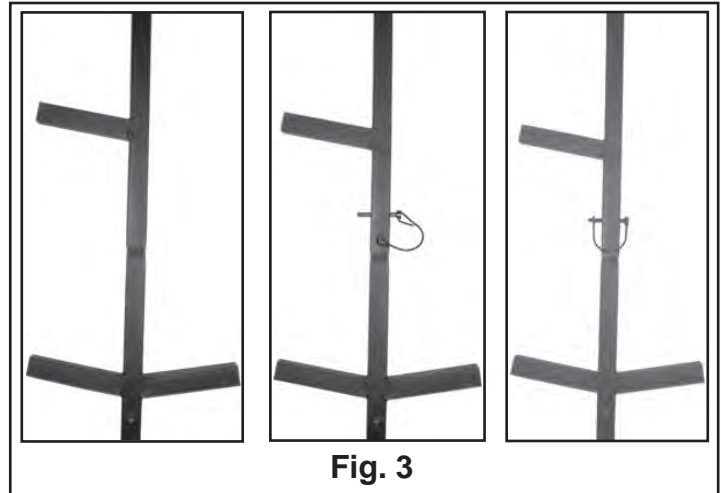
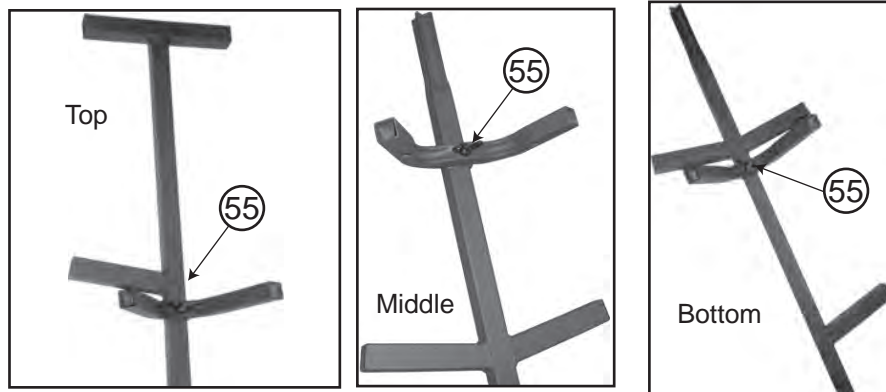

Fig. 3

3. The first step of the 2nd Middle Section should be facing the right hand side. Insert the male end of the 1st Middle Section into the 2nd Middle Section. Insert one quickclip through the hole.

The first step of the Top Section should be facing the left hand side. Insert the male end of the 2nd Middle Section into the female end of the Top Section. Insert one quickclip through the hole. Make sure all connections are tightened securely.



4. Attach Tree Brace **D** to each stick ladder section using 1 - **M12x55mm Bolt** for each section. Wingnut must be installed facing the tree. Tighten securely.

5. Assemble Buckle Straps **E** by following the **Detailed Buckle and Strap Instructions**. These straps will be hooked to one side on the tree brace and hang freely until the Stick Ladder is ready to be raised and secured to the tree.

Installation Instructions

MODEL: HEH00500
16' Climbing Stick

1. Make sure that the steps all angle upward. With the help of at least two other people, walk the assembled stick ladder up to the desired tree so that all of the Tree Braces are firmly against the tree. **(Fig. 5)** The stick ladder must be straight and vertical. **DO NOT** use on a leaning or dead tree. Tree should have a diameter between 9 and 18 inches.
2. Press your weight on the first step so that the base of the bottom section settles firmly and completely into the ground.
3. Wrap the Buckle Strap Assembly from the bottom section around the back of the tree and insert the hook into the other side of the Tree Brace. **(See Fig. 6)** Make sure that the strap is flat against tree with no slack. Secure section to the tree before climbing.
4. Attach Full Body Safety Harness with Climbing Belt to yourself and the tree according to the manufacturer's instructions.
5. Climb the bottom section of the stick ladder to reach the Second Section. Stand on the Bottom Section to attach the second strap to the Middle Section. Make sure section is secure before climbing any further.
6. Continue with step 5 for third and fourth sections.
7. When installing and removing stick ladder sections do not undo any strap until you are standing securely on the section below.

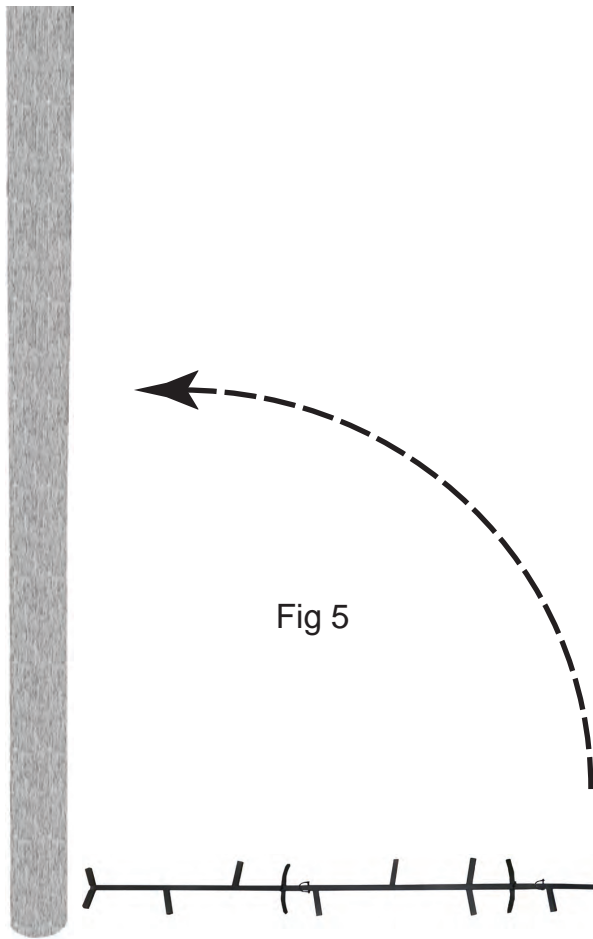

Fig 5

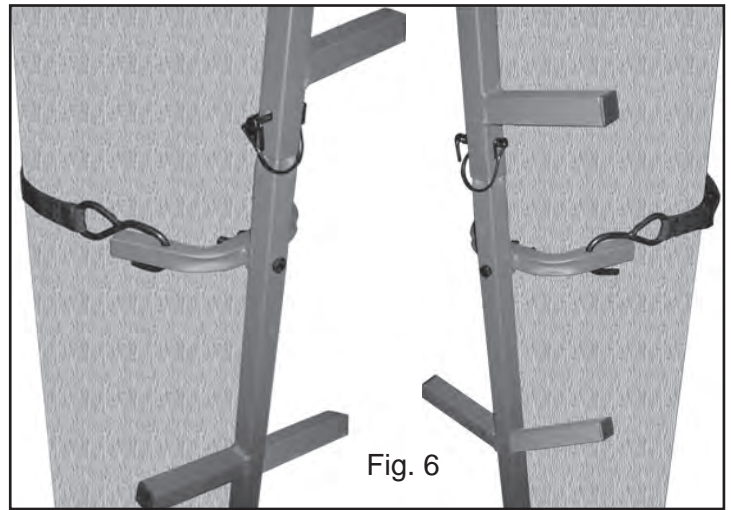
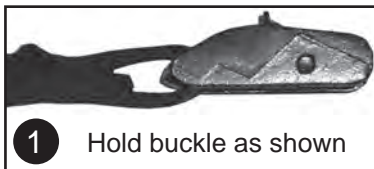
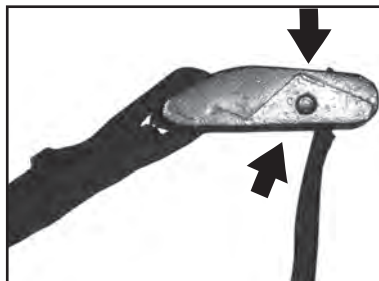

Fig. 6

Detailed Buckle and Strap Instructions



1 Hold buckle as shown



2 Press down on latch and insert strap underneath teeth as shown.



3 Pull strap to desired length.

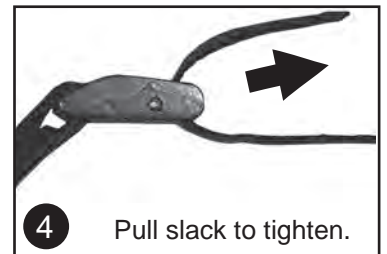

4 Pull slack to tighten.



WARNING

ALWAYS read and understand all warnings and instructions before each use of this product. Failure to read and understand all warnings and instructions may result in serious injury or death.

ALWAYS inspect the tree stand for signs of wear or damage **BEFORE** each use. Also inspect to ensure that nuts and bolts are secure and straps are not frayed, worn, or broken.

NEVER exceed weight limit of **300 lbs.** **DO NOT** use if your combined weight with all your hunting gear and any accessories exceeds **300 lbs.** Use of tree stand over the weight limit may result in serious injury or death.

ALWAYS wear a Fall Arrest System (FAS) consisting of a full body harness with lineman's belt after leaving the ground. You **MUST** stay connected at all times after leaving the ground. If you are not wearing an FAS, **DO NOT leave the ground.** Failure to wear an FAS may result in serious injury or death.

DO NOT use this tree stand while under the influence of alcohol, medication, or illegal substances. Use of tree stand while under the influence of any of these substances may result in serious injury or death.

NEVER use this tree stand if you have a history of health problems such as (*but not limited to*) heart problems, back problems, impaired vision, equilibrium impairments are afraid of heights or have been advised by a doctor not to do any strenuous activity. If you are feeling ill, nauseous, or dizzy **DO NOT** use this tree stand or If you are not physically fit, well rested and alert. Physical ailments can reduce your ability to safely install, utilize and remove your tree stand.

NEVER use this tree stand during inclement weather such as (but not limited to) thunderstorms, snowstorms, hurricanes, icy conditions, or high winds that could create slippery or dangerous situations.

NEVER use this tree stand on a dead, leaning, loose barked tree or on a utility pole as the tree may fall, break, or uproot and may result in serious injury or death.

NEVER leave the ground without checking every ladder section connection to ensure they are firmly connected. If ladder sections are separating, with the help of at least two other people, remove the tree stand from the tree, tighten all connections and reinstall on the tree.

NEVER step up to the platform. Climbing aids such as stick ladders, **MUST** extend above the platform of the hang-on to allow the user to step down on the platform. The Full Body Harness **MUST always** be attached to the tree even when stepping down into the tree stand.

DO NOT modify or alter your tree stand.

NEVER remove or deface warning labels.

FIELD & STREAM™