

Model: HEH00036

4ft Stick Ladder Extension

- Always Wear A Safety Harness With This Product
- Practice Using At Ground Level
- Weight Limit **300 lbs.**

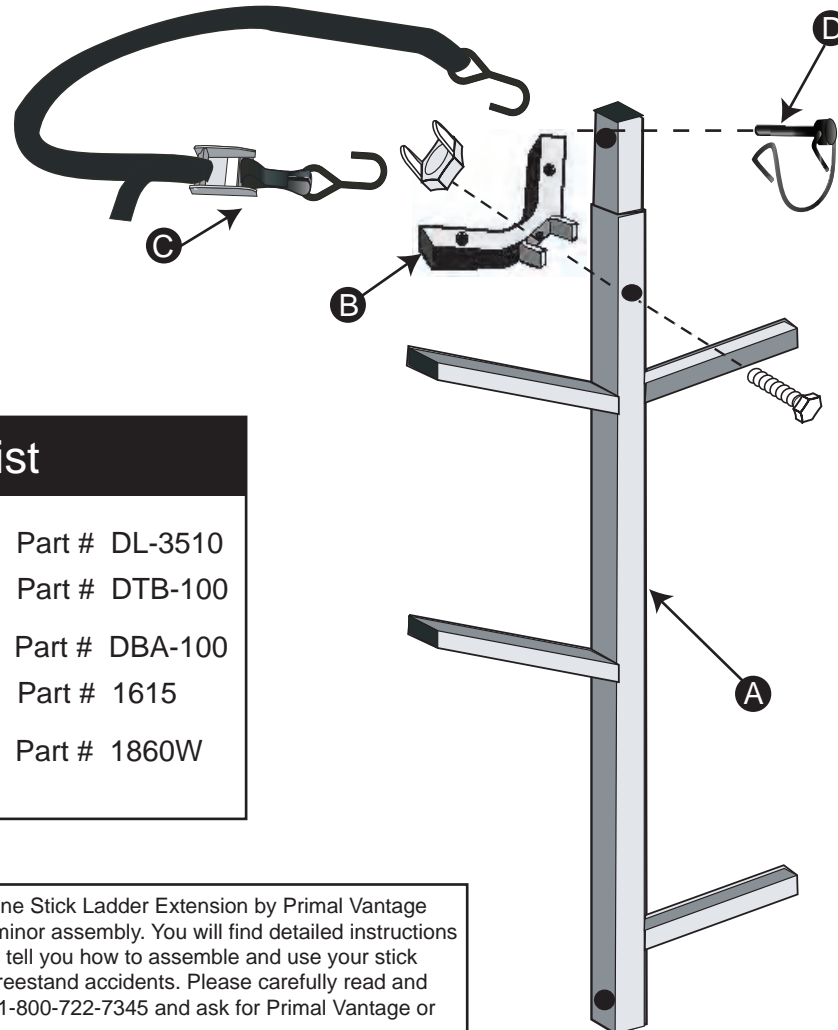

Parts List

A	1 Middle Section	Part # DL-3510
B	1 Tree Brace	Part # DTB-100
C	1 Buckle Strap Assy	Part # DBA-100
D	1 M6 Quickclip	Part # 1615
60	1 M8x60mm Bolt w/wingnut	Part # 1860W

Thank you for purchasing the Comfort Zone Stick Ladder Extension by Primal Vantage Company Inc. The stick ladder does require some minor assembly. You will find detailed instructions with your stick ladder. The following instructions will tell you how to assemble and use your stick ladder. Every year hunters are seriously injured in treestand accidents. Please carefully read and follow these instructions. For customer service call 1-800-722-7345 and ask for Primal Vantage or visit www.treestandcustomerservice.com.

Warning Warning

1. **ALWAYS** read all warnings and instructions before each use of stick ladder. Failure to read all warnings and instructions before each use of stick ladder may result in serious injury or death.
2. Remove all contents from box. Remove all cardboard from the product. Inspect for any damaged or missing pieces. **DO NOT** assemble or use stick ladder if any parts are missing or damaged. Using the stick ladder with missing or damaged parts may result in serious injury or death. Missing or damaged parts may be obtained from the address and phone number listed below.
3. **DO NOT** use stick ladder if any bolts or nuts are loose, bent or crooked.
4. Be sure to retighten all bolts before each new use of stick ladder.
5. Weight limit of this stick ladder is **300 lbs.** **DO NOT** use stick ladder if you or your combined weight with any accessories are more than **300 lbs.** Using this stick ladder when over **300 lbs.** may result in serious injury or death.
6. **ALWAYS** use a full body safety harness with climbing belt when using this stick ladder. Failure to use a full body safety harness with climbing belt may result in serious injury or death.
7. **NEVER** use stick ladder if you have dizzy spells, a heart condition, are afraid of heights, have been advised by a doctor or other healthcare provider not to climb, or have any condition that would impair your ability to climb up or down or use stick ladder as it could result in serious injury or death. Please consult a physician prior to use.
8. **DO NOT** use stick ladder under the influence of alcohol, medication, or any illegal substances. Using the stick ladder while under influence of any of these substances may result in serious injury or death.
9. **NEVER** use stick ladder during inclement weather. **DO NOT** use stick ladder during thunderstorms or any other weather conditions that included (but not limited to) lightning, freezing rain that could create slippery or dangerous conditions.
10. **DO NOT** use the stick ladder unless the ground is dry or level. Failure to use stick ladder when the ground is dry or level may result in serious injury or death.
11. **NEVER** use stick ladder on a tree that is dead, diseased, leaning, or on wet and uneven ground as the tree may fall, break, or uproot and may result in serious injury or death.
12. **DO NOT** leave your stick ladder outside all year round. It must be stored inside when not in use.
13. **NEVER** climb stick ladder with your weapon. Make sure that the unloaded firearm gun barrel is pointed toward the ground when raising or lowering it to your stand. Always use a safe hoist/lift system on the opposite side of the tree from which you are climbing.
14. **ALWAYS** unload your weapon and use safety lock while raising or lowering your weapon. Failure to unload your weapon may result in serious injury or death.
15. Use stick ladder on trees with a minimum diameter of 9" and maximum of 20".
16. **ALWAYS** have a communication device on your person and easily accessible. Immediate access to another person may save your life. In the event of an accident, a rescue plan must be in place and able to be incorporated immediately.

HEH00036 Climbing Stick Extension Assembly Instructions

Warning ⚠ **Warning** ⚠ **Warning** ⚠

1. Attach Tree Brace **B** to the Stick Ladder Extension **A** using **1-M8x60mm bolt**. Wingnut must be installed for the tree brace side. **(See Fig. 1)**
2. Lie your current stick ladder along the ground and insert the extension into the highest ladder section of your stick ladder. Insert **1-Quickclip** into the new section at the insertion point. **(See Fig. 2)**
3. With the help of at least **TWO** other people, raise your stick ladder and sit the entire stick ladder firmly to the tree. Press on the bottom most step of the first section with your foot to ensure the stick ladder has settled onto the ground.
4. Attach Buckle Strap Assembly **C** to the first section's tree brace by inserting the hook into one of the holes on the tree brace. Wrap the buckle strap around the tree after feeding the strap through the buckle **(See Buckle Strap Instructions)**. Hook the other hook to the opposite side of the tree brace. Pull extra slack through the buckle to tightly secure the stick ladder to the tree. **(See Fig. 3)**
5. Attach your harness with climbing belt to the tree **(See Manufacturers Instructions)**.
6. Climb to the second ladder section tree brace, be sure you are only standing on the first ladder section that has already been strapped to the tree.
7. Secure the 2nd ladder section using a buckle strap assembly following Step 4 of these instructions.
8. Repeat this process for the remaining sections.
9. To remove your stick ladder climb so that your feet are on the fourth ladder section and remove the buckle strap from the 5th ladder section.
10. Continue down your stick removing buckle straps each time you are standing on the ladder section below.
11. Remove the final buckle strap from the bottom ladder section when you are standing on the ground.

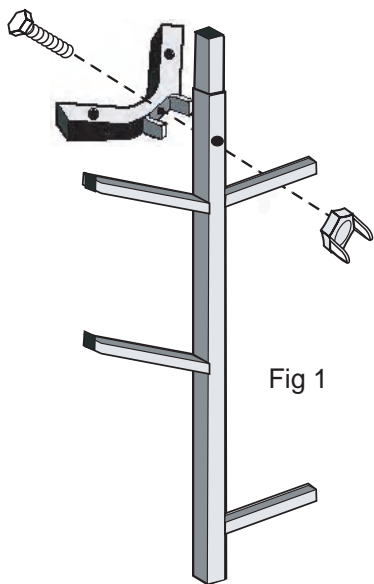

Fig 1

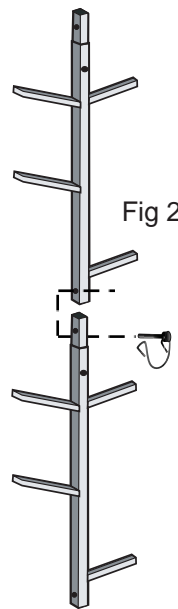

Fig 2

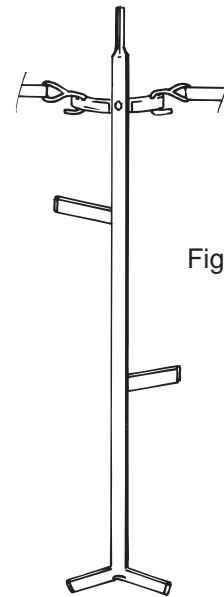

Fig 3

1. **ALWAYS** read all warnings and instructions before each use of stick ladder. Failure to read all warnings and instructions before each use of stick ladder may result in serious injury or death.
2. Remove all contents from box. remove all cardboard from the product. Inspect for any damaged or missing pieces. **DO NOT** assemble or use stick ladder if any parts are missing or damaged. Using the stick ladder with missing or damaged parts may result in serious injury or death. Missing or damaged parts may be obtained from the address and phone number listed below.
3. **DO NOT** use stick ladder if any bolts or nuts are loose, bent or crooked.
4. Be sure to retighten all bolts before each new use of stick ladder.
5. Weight limit of this stick ladder is **300 lbs.** **DO NOT** use stick ladder if you or your combined weight with any equipment exceeds **300 lbs.**
6. **ALWAYS** use a full body safety harness with climbing belt when using this stick ladder. Failure to use a safety harness with climbing belt may result in serious injury or death.
7. **NEVER** use stick ladder if you have dizzy spells, a heart condition, are afraid of heights, have been advised by a doctor or other healthcare provider not to climb, or have any condition that would impair your ability to climb up or down or use stick ladder as it could result in serious injury or death. Please consult a physician prior to use.
8. **DO NOT** use stick ladder under the influence of alcohol, medication, or any illegal substances. Using the stick ladder while under influence of any of these substances may result in serious injury or death.
9. **NEVER** use stick ladder during inclement weather. **DO NOT** use stick ladder during thunderstorms or any other weather conditions that include (but not limited to) lightning, freezing rain that could create slippery or dangerous conditions.
10. **DO NOT** use the stick ladder unless the ground is dry or level. Failure to use stick ladder when the ground is dry or level may result in serious injury or death.
11. **NEVER** use stick ladder on a tree that is dead, diseased, leaning, or on wet and uneven ground as the tree may fall, break, or uproot and may result in serious injury or death.
12. **DO NOT** leave your stick ladder outside all year round. It must be stored inside when not in use.
13. **NEVER** climb stick ladder with your weapon. Make sure that the unloaded firearm gun barrel is pointed toward the ground when raising or lowering it to your stand. Always use a safe hoist/lift system on the opposite side of the tree from which you are climbing.
14. **ALWAYS** unload your weapon and use safety lock while raising or lowering your weapon. Failure to unload your weapon may result in serious injury or death.
15. Use stick ladder on trees with a minimum diameter of 9" and maximum of 20".
16. **ALWAYS** have a communication device on your person and easily accessible. Immediate access to another person may save your life. In the event of an accident, a rescue plan must be place and able to be incorporated immediately.
17. **DO NOT** fall asleep in your stand as you may potentially fall out resulting in serious injury or death.

HEH00036 Climbing Stick Extension Assembly Instructions

Warning ⚠ **Warning** ⚠ **Warning** ⚠

1. Stand the assembled stick ladder upright next to the tree so that all of the Tree Braces are firmly against the tree. **(Fig. 5)** The stick ladder must be straight and vertical. **DO NOT** use on a leaning or dead tree. Tree should have a diameter between 9 and 20 inches.
2. Press your weight on the first step so that the base of the bottom section settles firmly and completely into the ground.
3. Attach each hook of the Buckle Strap Assembly to the Tree Brace **D** **(Fig.6)** and wrap the strap around the back of the tree. Make sure that the strap is flat against tree with no slack. **(Fig. 3)**. Then securely fasten to tree brace **(See Detailed S-hook Buckle and Strap Instructions)**. Secure section to the tree before climbing.
4. Attach Safety Harness to yourself and the tree according to the manufacturer's instructions.
5. Climb the bottom section of the stick ladder to reach the Second Section. Attach the second strap. Make sure section is secure before climbing any further.
6. Repeat for third and fourth sections.
7. When installing and removing stick ladder sections do not undo any strap until you are standing securely on the section below.

1. **ALWAYS** read all warnings and instructions before each use of stick ladder. Failure to read all warnings and instructions before each use of stick ladder may result in serious injury or death.
2. Remove all contents from box. Remove all cardboard from the product. Inspect for any damaged or missing pieces. **DO NOT** assemble or use stick ladder if any parts are missing or damaged. Using the stick ladder with missing or damaged parts may result in serious injury or death. Missing or damaged parts may be obtained from the address and phone number listed below.
3. **DO NOT** use stick ladder if any bolts or nuts are loose, bent or crooked.
4. Be sure to retighten all bolts before each new use of stick ladder.
5. Weight limit of this stick ladder is **300 lbs**. **DO NOT** use stick ladder if you or your combined weight with any accessories are more than **300 lbs**. Using this stick ladder when over **300 lbs**. may result in serious injury or death.
6. **ALWAYS** use a full body safety harness with climbing belt when using this stick ladder. Failure to use a full body safety harness with climbing belt may result in serious injury or death.
7. **NEVER** use stick ladder if you have dizzy spells, a heart condition, are afraid of heights, have been advised by a doctor or other healthcare provider not to climb, or have any condition that would impair your ability to climb up or down or use stick ladder as it could result in serious injury or death. Please consult a physician prior to use.
8. **DO NOT** use stick ladder under the influence of alcohol, medication, or any illegal substances. Using the stick ladder while under influence of any of these substances may result in serious injury or death.
9. **NEVER** use stick ladder during inclement weather. **DO NOT** use stick ladder during thunderstorms or any other weather conditions that included (but not limited to) lightning, freezing rain that could create slippery or dangerous conditions.
10. **DO NOT** use the stick ladder unless the ground is dry or level. Failure to use stick ladder when the ground is dry or level may result in serious injury or death.
11. **NEVER** use stick ladder on a tree that is dead, diseased, leaning, or on wet and uneven ground as the tree may fall, break, or uproot and may result in serious injury or death.
12. **DO NOT** leave your stick ladder outside all year round. It must be stored inside when not in use.
13. **NEVER** climb stick ladder with your weapon. Make sure that the unloaded firearm gun barrel is pointed toward the ground when raising or lowering it to your stand. Always use a safe hoist/lift system on the opposite side of the tree from which you are climbing.
14. **ALWAYS** unload your weapon and use safety lock while raising or lowering your weapon. Failure to unload your weapon may result in serious injury or death.
15. Use stick ladder on trees with a minimum diameter of 9" and maximum of 20".
16. **ALWAYS** have a communication device on your person and easily accessible. Immediate access to another person may save your life. In the event of an accident, a rescue plan must be in

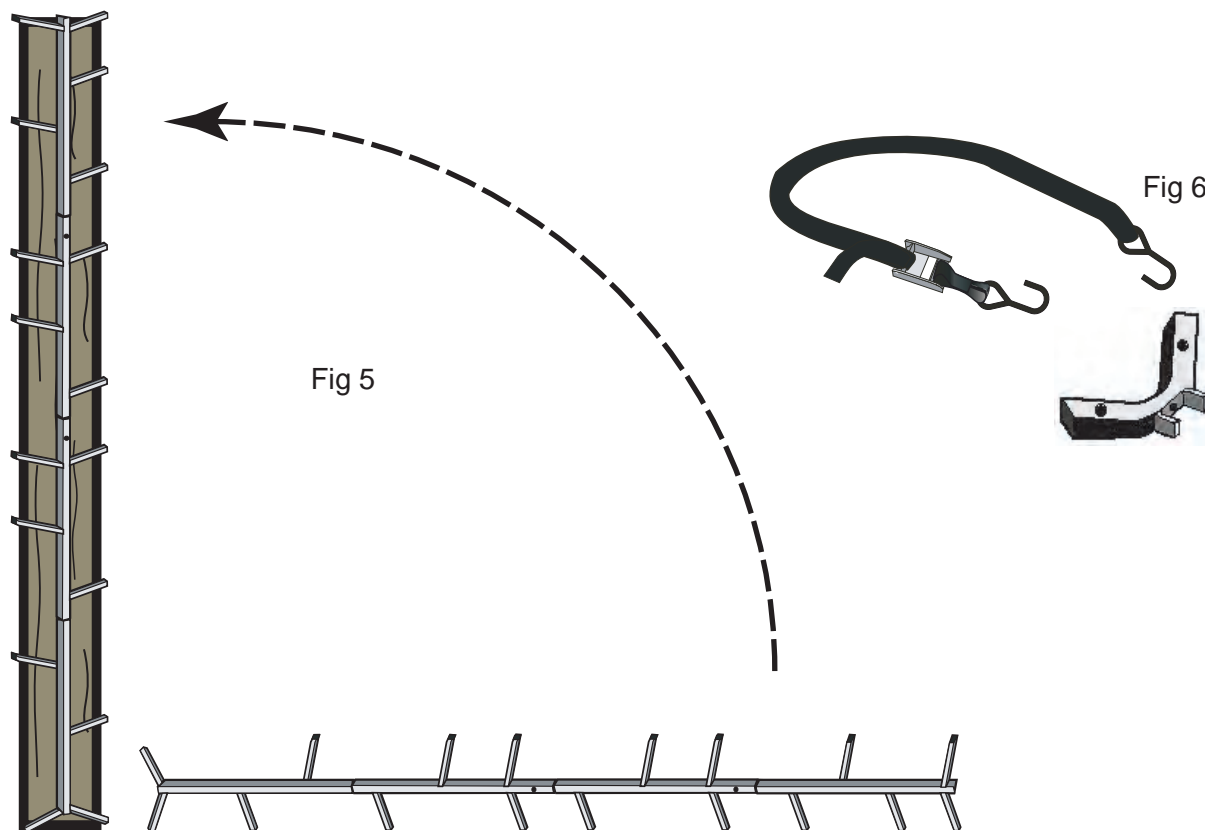

DETAILED S-HOOK BUCKLE AND STRAP INSTRUCTIONS

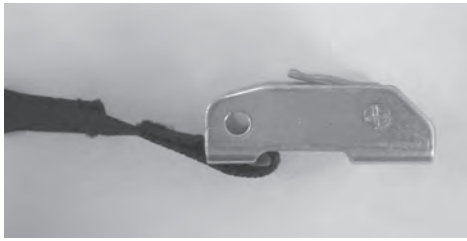

Fig. 1

1. Hold buckle as shown in (Fig. 1)

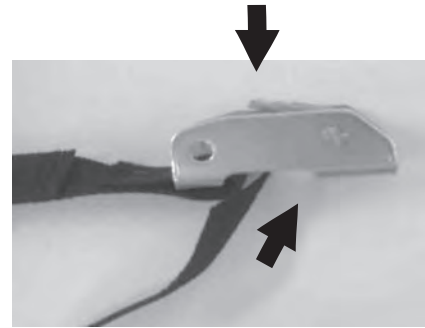

Fig. 2

2. Press down on latch and insert strap underneath teeth and flat piece of metal as shown in (Fig. 2).



Fig. 3

3. Pull strap to desired length. (Fig. 3)

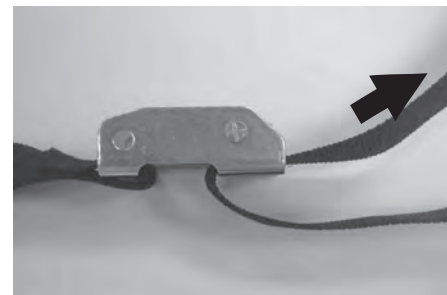

Fig. 4

4. Wrap strap around tree and insert hooks into holes on tree brace. Pull slack until tightened. (Fig. 4)

Always tug on strap to make sure it is secured by the buckle