

Model: SGTS-EXT

# 3Ft Tripod Extension

- Weight Limit **300 lbs.**
- Do Not Over Tighten Fasteners

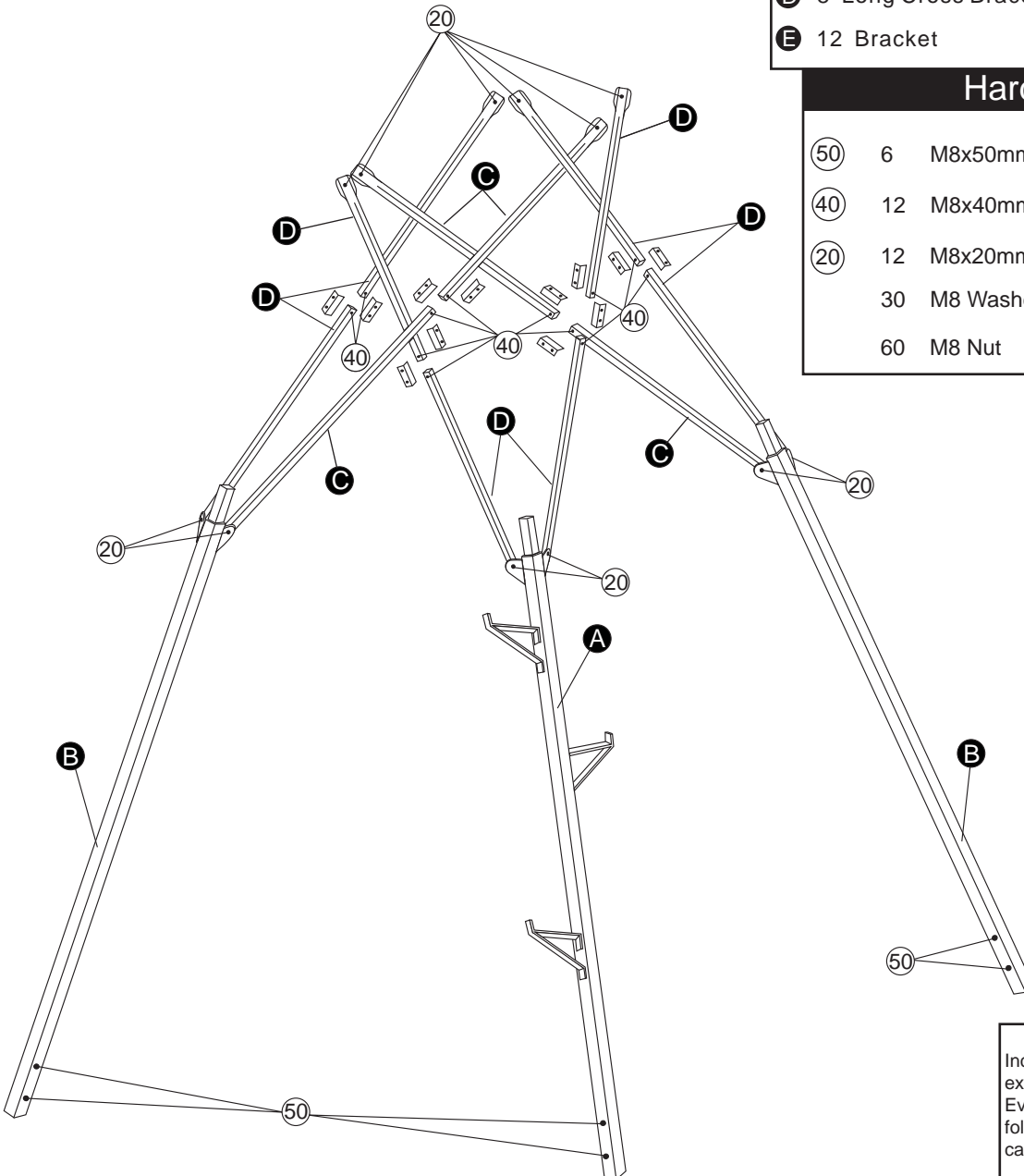

## Parts List

<b>A</b>	1 Bottom Ladder Section	Part # GL-300
<b>B</b>	2 Bottom Leg	Part # GL-350
<b>C</b>	4 Short Cross Brace 41.5"	Part # GCB-300
<b>D</b>	8 Long Cross Brace 47.1"	Part # GCB-350
<b>E</b>	12 Bracket	Part # GB-300

## Hardware

50	6	M8x50mm Bolt	Part # 1850
40	12	M8x40mm Bolt	Part # 1840
20	12	M8x20mm Bolt	Part # 1820
	30	M8 Washer	Part # 1800
	60	M8 Nut	Part # 1810

⚠ Warning ⚠ Warning ⚠ Warning ⚠ Warning ⚠

1. **ALWAYS** read all warnings and instructions before each use of tripod. Failure to read all warnings and instructions before each use of tripod may result in serious injury or death.
2. Remove all contents from box. Remove all cardboard from the product. Inspect for any damaged or missing pieces. **DO NOT** assemble or use tripod if any parts are missing or damaged. Using the tripod with missing or damaged parts may result in serious injury or death. Missing or damaged parts may be obtained from the address and phone number listed below.
3. **DO NOT** use tripod if any bolts or nuts are loose, bent or crooked.
4. Be sure to retighten all bolts before each new use of tripod.
5. Weight limit of this tripod is **300 lbs.** **DO NOT** use tripod if you or your combined weight with any accessories are more than **300 lbs.** Using this tripod when over **300 lbs.** may result in serious injury or death.
6. **NEVER** use tripod if you have dizzy spells, a heart condition, are afraid of heights, have been advised by a doctor or other healthcare provider not to climb, or have any condition that would impair your ability to climb up or down or use tripod as it could result in serious injury or death. Please consult a physician prior to use.
7. **DO NOT** use tripod under the influence of alcohol, medication, or any illegal substances. Using the tripod while under influence of any of these substances may result in serious injury or death.
8. **NEVER** use tripod during inclement weather. **DO NOT** use tripod during thunderstorms or any other weather conditions that included (but not limited to) lightning, freezing rain that could create slippery or dangerous conditions.
9. **DO NOT** use the tripod unless the ground is dry or level. Failure to use tripod when the ground is dry or level may result in serious injury or death.
10. **DO NOT** leave your tripod outside all year round. It must be stored inside when not in use.
11. **NEVER** climb tripod with your weapon. Make sure that the unloaded firearm gun barrel is pointed toward the ground when raising or lowering it to your stand. Always use a safe hoist/lift system on the opposite side of the tree from which you are climbing.
12. **ALWAYS** unload your weapon and use safety lock while raising or lowering your weapon. Failure to unload your weapon may result in serious injury or death.
13. **ALWAYS** have a communication device on your person and easily accessible. Immediate access to another person may save your life. In the event of an accident, a rescue plan must be in place and able to be incorporated immediately.
14. **DO NOT** fall asleep in your stand as you may potentially fall out resulting in serious injury or death.

Thank you for purchasing the Tripod Extension Kit by Primal Vantage Company Inc. The extension does require some assembly. You will find detailed instructions with your extension. The following instructions will tell you how to assemble and use your extension. Every year hunters are seriously injured in treestand accidents. Please carefully read and follow these instructions. For customer service visit [www.treestandcustomerservice.com](http://www.treestandcustomerservice.com) or call 1-800-722-7345 and ask for Primal Vantage.

# SGTS-EXT Assembly Instructions Page 2

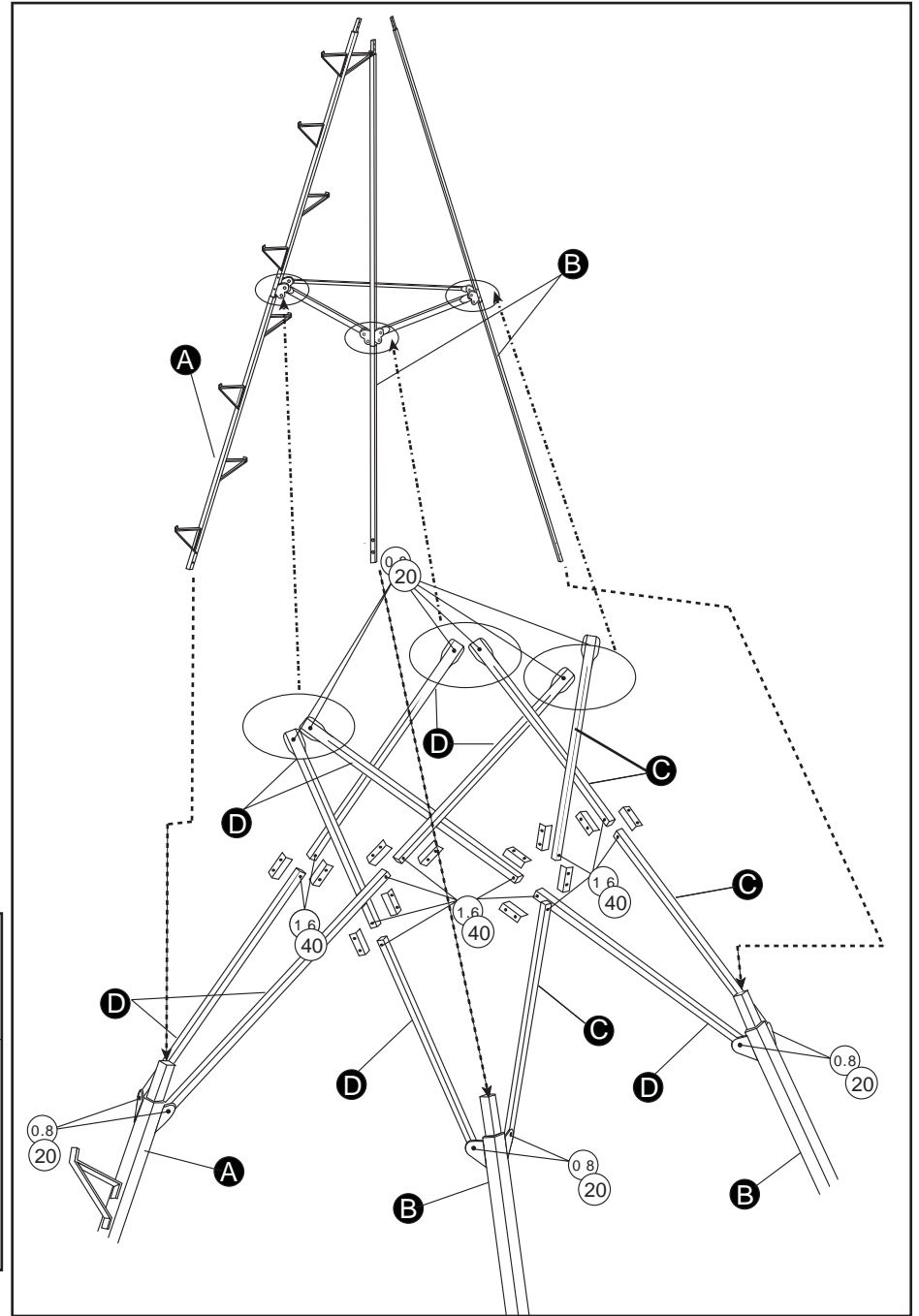
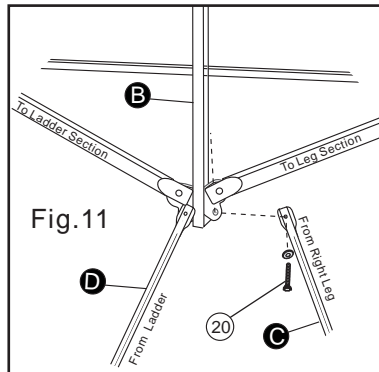
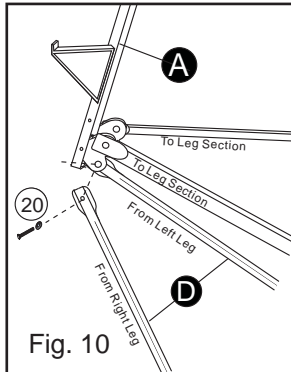
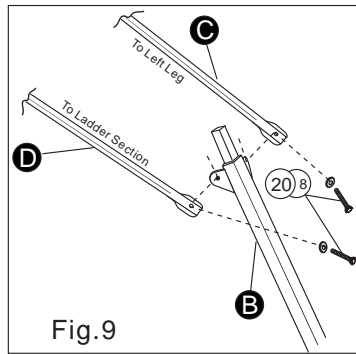
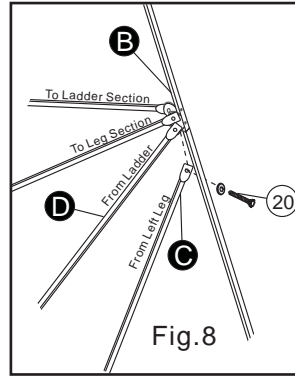
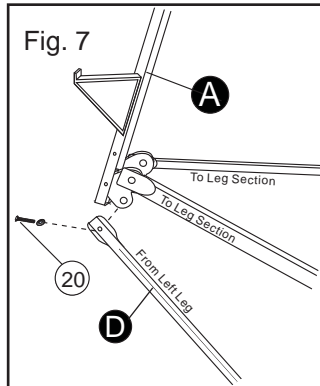
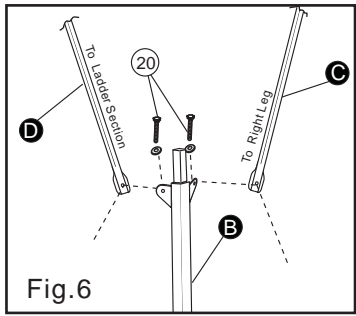
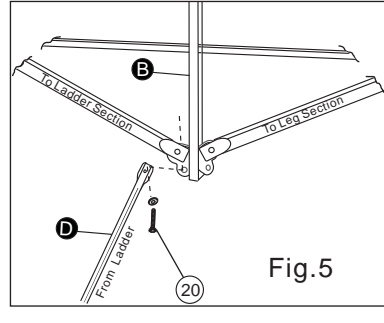
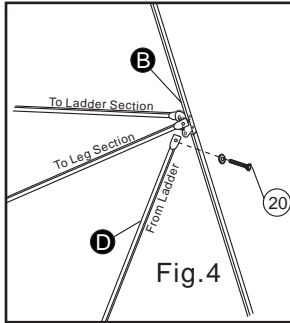
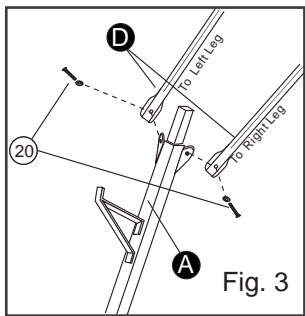
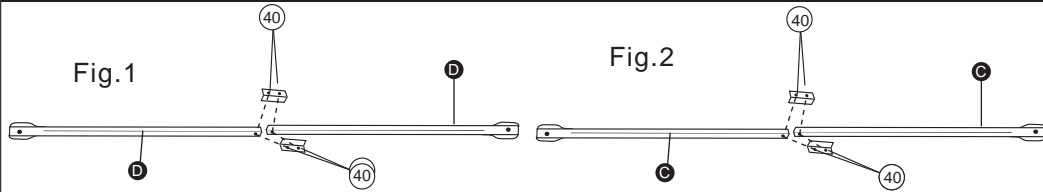

## SGTS-EXT 3ft Tripod Extension Assembly

1. With the help of at least two other people lay the **SGTS-13R Tripod** on the ground. Remove the bolts holding the feet in place. Store these for use in future steps.
2. Insert the flanged end of the bottom Ladder Section **(A)** into the original ladder section. Use **2-50mm bolts** to attach the ladder sections together. (Make sure the flanges are on the inside of the tripod.)
3. Insert the flanged end of each new bottom Leg Section **(B)** in to the original legs. Use **2-50mm bolts** for each leg.
4. Insert the feet back into the new bottom sections and attach them using the bolts you removed.
5. Assemble all **(D)** Braces together using 2 Brackets **(E)** and **2-40mm bolts** for each brace assembly. (You will have four **(D)** Brace Assemblies) **(See Fig. 1)**
6. Assemble all **(C)** Braces together using 2 Brackets **(E)** and **2-40mm bolts** for each brace assembly. (You will have two **(C)** Brace Assemblies.) **(See Fig. 2)**
7. Attach two **(D)** Brace Assemblies to the Bottom Ladder Section **(A)** at the flanges using **1-20mm bolt** for each brace. **(See Fig. 3)**
8. The right one attaches to the upper right leg, bottom right hand flange. **(See Fig. 4)** The left one attaches to the upper left leg, bottom left hand flange. **(See Fig. 5)** Use **1-20mm Bolt** at each attachment point.
9. Attach one **(D)** Brace Assembly to the lower left leg on the left hand flange and one **(C)** Brace Assembly to the right hand flange using **1-20mm bolt**. **(See Fig. 6)**
10. The **(D)** Brace Assembly will attach to the upper Ladder Section at the bottom left hand flange. **(See Fig. 7)** The **(C)** Brace Assembly will attach to the upper Right Leg bottom left hand flange. Use **1-20mm bolt** for each. **(See Fig. 8)**
11. Attach one **(D)** Brace Assembly to the lower right leg on the right hand flange and one **(C)** Brace Assembly to the left hand flange. Use **1-20mm bolt** at each attachment point. **(See Fig. 9)**
12. The **(D)** Brace Assembly will attach to the upper Ladder Section at the bottom right hand flange. **(See Fig. 10)** The **(C)** Brace Assembly will attach to the upper Left Leg bottom right hand flange. Use **1-20mm bolt** for each. **(See Fig. 11)**

### ⚠ Warning ⚠ Warning ⚠ Warning ⚠ Warning ⚠ Warning ⚠ Warning ⚠ Warning ⚠

1. **ALWAYS** read all warnings and instructions before each use of tripod. Failure to read all warnings and instructions before each use of tripod may result in serious injury or death.
2. Remove all contents from box. Remove all cardboard from the product. Inspect for any damaged or missing pieces. **DO NOT** assemble or use tripod if any parts are missing or damaged. Using the tripod with missing or damaged parts may result in serious injury or death. Missing or damaged parts may be obtained from the address and phone number listed below.
3. **DO NOT** use tripod if any bolts or nuts are loose, bent or crooked.
4. Be sure to retighten all bolts before each new use of tripod.
5. Weight limit of this tripod is **300 lbs**. **DO NOT** use tripod if you or your combined weight with any accessories are more than **300 lbs**. Using this tripod when over **300 lbs**. may result in serious injury or death.
6. **NEVER** use tripod if you have dizzy spells, a heart condition, are afraid of heights, have been advised by a doctor or other healthcare provider not to climb, or have any condition that would impair your ability to climb up or down or use tripod as it could result in serious injury or death. Please consult a physician prior to use.
7. **DO NOT** use tripod under the influence of alcohol, medication, or any illegal substances. Using the tripod while under influence of any of these substances may result in serious injury or death.
8. **NEVER** use tripod during inclement weather. **DO NOT** use tripod during thunderstorms or any other weather conditions that included (but not limited to) lightning, freezing rain that could create slippery or dangerous conditions.
9. **DO NOT** use the tripod unless the ground is dry or level. Failure to use tripod when the ground is dry or level may result in serious injury or death.
10. **DO NOT** leave your tripod outside all year round. It must be stored inside when not in use.
11. **NEVER** climb tripod with your weapon. Make sure that the unloaded firearm gun barrel is pointed toward the ground when raising or lowering it to your stand. Always use a safe hoist/lift system on the opposite side of the tree from which you are climbing.
12. **ALWAYS** unload you weapon and use safety lock while raising or lowering your weapon. Failure to unload your weapon may result in serious injury or death.
13. **ALWAYS** have a communication device on your person and easily accessible. Immediate access to another person may save your life. In the event of an accident, a rescue plan must be in place and able to be incorporated immediately.
14. **DO NOT** fall asleep in your stand as you may potentially fall out resulting in serious injury or death.