

Model: SGSL-121

## 20ft Mini-Ladder

- Always Wear A Safety Harness With This Product
- Practice Using At Ground Level
- Weight Limit **300 lbs.**

### Parts List

<b>A</b>	5 Ladder Section	Part # GL-1000
<b>B</b>	5 Tree Brace	Part # GTB-1250
<b>C</b>	5 Buckle Strap Assy	Part # GBA-100
<b>45</b>	4 M8x45mm Bolt w/wingnut	Part # 1845W



Thank you for purchasing the Sportsman's Mini Ladder by Primal Vantage Company Inc. The Mini Ladder requires some assembly. You will find detailed instructions with your Mini Ladder. The following instructions will tell you how to assemble and use your Mini Ladder. Every year hunters are seriously injured in treestand accidents. Please carefully read and follow these instructions. For missing or damaged parts visit [www.treestandcustomerservice.com](http://www.treestandcustomerservice.com) or call 1-800-722-7345 and ask for Primal Vantage.

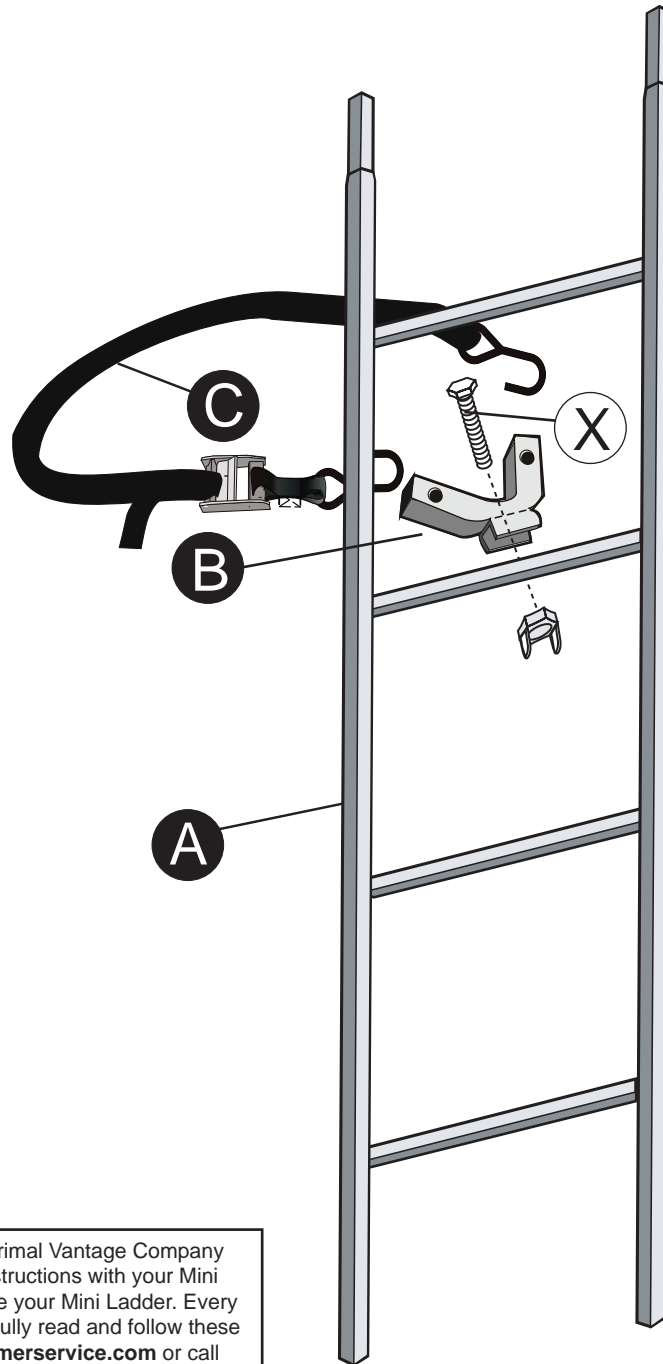

### Warning Warning

1. **ALWAYS** read all warnings and instructions before each use of mini ladder. Failure to read all warnings and instructions before each use of mini ladder may result in serious injury or death.
2. Remove all contents from box. remove all cardboard from the product. Inspect for any damaged or missing pieces. **DO NOT** assemble or use mini ladder if any parts are missing or damaged. Using the mini ladder with missing or damaged parts may result in serious injury or death. Missing or damaged parts may be obtained from the address and phone number listed below.
3. **DO NOT** use mini ladder if any bolts or nuts are loose, bent or crooked.
4. Be sure to retighten all bolts before each new use of mini ladder.
5. Weight limit of this mini ladder is **300 lbs.** **DO NOT** use mini ladder if you or your combined weight with any equipment exceeds **300 lbs.**
6. **ALWAYS** use a full body safety harness with climbing belt when using this mini ladder. Failure to use a safety harness with climbing belt may result in serious injury or death.
7. **NEVER** use mini ladder if you have dizzy spells, a heart condition, are afraid of heights, have been advised by a doctor or other healthcare provider not to climb, or have any condition that would impair your ability to climb up or down or use mini ladder as it could result in serious injury or death. Please consult a physician prior to use.
8. **DO NOT** use mini ladder under the influence of alcohol, medication, or any illegal substances. Using the mini ladder while under influence of any of these substances may result in serious injury or death.
9. **NEVER** use mini ladder during inclement weather. **DO NOT** use mini ladder during thunderstorms or any other weather conditions that include (but not limited to) lightning, freezing rain that could create slippery or dangerous conditions.
10. **DO NOT** use the mini ladder unless the ground is dry or level. Failure to use mini ladder when the ground is dry or level may result in serious injury or death.
11. **NEVER** use mini ladder on a tree that is dead, diseased, leaning, or on wet and uneven ground as the tree may fall, break, or uproot and may result in serious injury or death.
12. **DO NOT** leave your mini ladder outside all year round. It must be stored inside when not in use.
13. **NEVER** climb mini ladder with your weapon. Make sure that the unloaded firearm gun barrel is pointed toward the ground when raising or lowering it to your stand. Always use a safe hoist/lift system on the opposite side of the tree from which you are climbing.
14. **ALWAYS** unload your weapon and use safety lock while raising or lowering your weapon. Failure to unload your weapon may result in serious injury or death.
15. Use mini ladder on trees with a minimum diameter of 9" and maximum of 20".
16. **ALWAYS** have a communication device on your person and easily accessible. Immediate access to another person may save your life. In the event of an accident, a rescue plan must be place and able to be incorporated immediately.
17. **DO NOT** fall asleep in your stand as you may potentially fall out resulting in serious injury or death.

# SGSL-121 20 Ft Mini Ladder Assembly Instructions

## ⚠ WARNING ⚠ WARNING ⚠

1. Attach Tree Brace **B** to Mini Ladder Section **A** using **1-M8x45mm Bolt with wingnut**. Wingnuts must be installed facing away from tree. **(Fig. 1)**. Tighten securely.
2. Assemble all ladder sections together **(Fig. 2)**. Make sure all connections are tightened securely.
3. Stand the assembled Mini Ladder upright against the tree so that all of the Tree Braces are firmly against the tree. The Mini Ladder must be straight and vertical. **DO NOT** use on a leaning or dead tree. Tree should have a diameter between 9 and 20 inches.
4. Press your weight on the first step so that the base of the bottom section settles firmly and completely into the ground.
5. Attach Buckle Strap Assembly **C** to Tree Brace **B**. **(See Fig. 3)**. Insert the hook into one of the holes on the tree brace. Wrap the strap around the back of the tree. Insert the other hook into the other hole on the tree brace. Make sure that the strap is flat against tree with no slack. **(Fig. 3)**. **(See Detailed S-hook Buckle and Strap Instructions)**. Pull the strap tight to secure section to the tree before climbing.
6. Attach Safety Harness to yourself and the tree according to the manufacturer's instructions.
7. Climb the bottom section of the Mini Ladder to reach the Second Section. Attach the second strap. Make sure section is secure before climbing any further.
8. Repeat for each remaining section.
9. When removing mini ladder sections do not undo any strap until you are standing securely on the section below it.

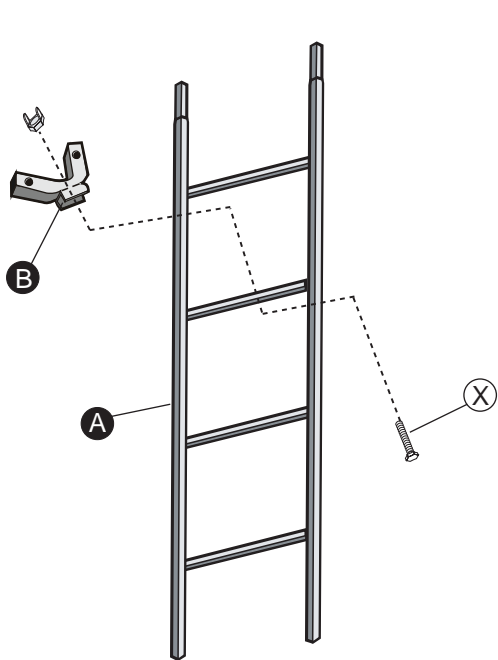

Fig 1

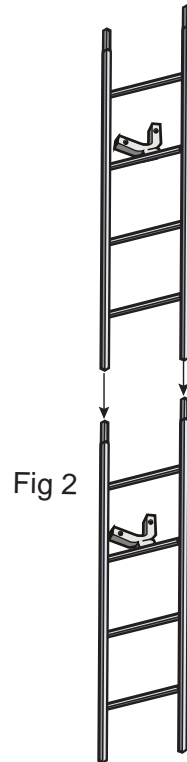

Fig 2

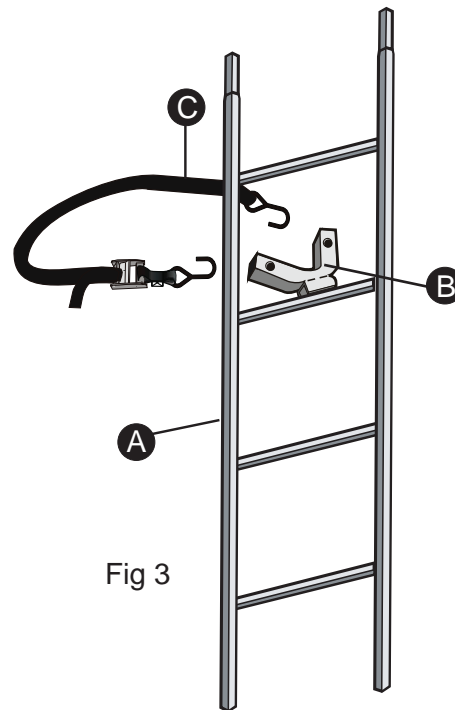

Fig 3

1. **ALWAYS** read all warnings and instructions before each use of mini ladder. Failure to read all warnings and instructions before each use of mini ladder may result in serious injury or death.
2. Remove all contents from box. remove all cardboard from the product. Inspect for any damaged or missing pieces. **DO NOT** assemble or use mini ladder if any parts are missing or damaged. Using the mini ladder with missing or damaged parts may result in serious injury or death. Missing or damaged parts may be obtained from the address and phone number listed below.
3. **DO NOT** use mini ladder if any bolts or nuts are loose, bent or crooked.
4. Be sure to retighten all bolts before each new use of mini ladder.
5. Weight limit of this mini ladder is **300 lbs.** **DO NOT** use mini ladder if you or your combined weight with any equipment exceeds **300 lbs.**
6. **ALWAYS** use a full body safety harness with climbing belt when using this mini ladder. Failure to use a safety harness with climbing belt may result in serious injury or death.
7. **NEVER** use mini ladder if you have dizzy spells, a heart condition, are afraid of heights, have been advised by a doctor or other healthcare provider not to climb, or have any condition that would impair your ability to climb up or down or use mini ladder as it could result in serious injury or death. Please consult a physician prior to use.
8. **DO NOT** use mini ladder under the influence of alcohol, medication, or any illegal substances. Using the mini ladder while under influence of any of these substances may result in serious injury or death.
9. **NEVER** use mini ladder during inclement weather. **DO NOT** use mini ladder during thunderstorms or any other weather conditions that include (but not limited to) lightning, freezing rain that could create slippery or dangerous conditions.
10. **DO NOT** use the mini ladder unless the ground is dry or level. Failure to use mini ladder when the ground is dry or level may result in serious injury or death.
11. **NEVER** use mini ladder on a tree that is dead, diseased, leaning, or on wet and uneven ground as the tree may fall, break, or uproot and may result in serious injury or death.
12. **DO NOT** leave your mini ladder outside all year round. It must be stored inside when not in use.
13. **NEVER** climb mini ladder with your weapon. Make sure that the unloaded firearm gun barrel is pointed toward the ground when raising or lowering it to your stand. Always use a safe hoist/lift system on the opposite side of the tree from which you are climbing.
14. **ALWAYS** unload your weapon and use safety lock while raising or lowering your weapon. Failure to unload your weapon may result in serious injury or death.
15. Use mini ladder on trees with a minimum diameter of 9" and maximum of 20".
16. **ALWAYS** have a communication device on your person and easily access ble. Immediate access to another person may save your life. In the event of an accident, a rescue plan must be place and able to be incorporated immediately.
17. **DO NOT** fall asleep in your stand as you may potentially fall out resulting in serious injury or death.

# DETAILED S-HOOK BUCKLE AND STRAP INSTRUCTIONS



Fig. 1

1. Hold buckle as shown in (Fig. 1)

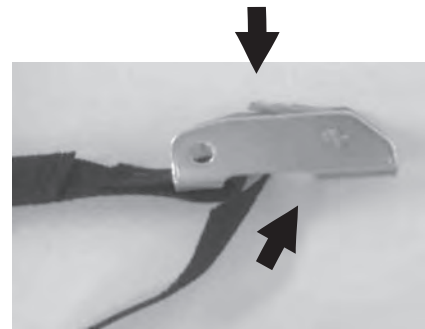

Fig. 2

2. Press down on latch and insert strap underneath teeth and flat piece of metal as shown in (Fig. 2).



Fig. 3

3. Pull strap to desired length. (Fig. 3)

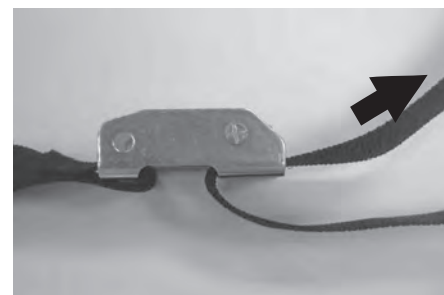

Fig. 4

4. Wrap strap around tree and insert hooks into holes on tree brace. Pull slack until tightened. (Fig. 4)

**Always** tug on strap to make sure it is secured by the buckle